



Advanced in Engineering and Intelligence Systems

Journal Web Page: <https://aeis.bilijipub.com>



Study of Atmospheric Discharge Effects in Distribution Networks with a Novel Residential Buildings Protection Approach

Meisam Karami¹, Yazdan Ashgevari^{1,*}

¹ Department of electrical engineering, Ardabil Branch, Islamic Azad University, Ardabil, Iran

Highlights

- Investigation of lightning overvoltage in low voltage lines for different scenarios
- Investigation of voltages generate caused by lightning strikes in different parts of the building
- Using simulations of past research on electrical equipment and comparing the results of different scenarios

Article Info

Received: 21 May 2023
 Received in revised: 14 June 2023
 Accepted: 17 June 2023
 Available online: 18 June 2023

Keywords

Direct Lightning Discharge,
 Ground Potential,
 Lightning Induced Voltage,
 Low voltage Lines.

Abstract

Lightning-induced overvoltage poses a significant threat to electrical equipment and building structures. This study aims to comprehensively investigate lightning overvoltage in low voltage distribution lines under different scenarios, including lightning strikes to the ground, direct discharge through distribution lines, and direct discharge through antennas. The MATLAB simulation program is employed for conducting simulations, and the results reveal noteworthy findings. Specifically, the analysis demonstrates that the magnitude of overvoltage resulting from lightning discharge through distribution lines and antennas surpasses that observed from discharge to the ground. Furthermore, the study explores lightning strikes occurring in the vicinity of buildings, leading to a rise in ground potential and indicating the potential reverse flow of lightning current from the ground system towards the building. By shedding light on these phenomena, this research contributes to a deeper understanding of lightning overvoltage behavior and aids in the development of effective mitigation strategies for safeguarding electrical systems and building infrastructure.

1. Introduction

The damage caused by lightning to electrical appliances is increasingly becoming a complex phenomenon. Previous investigations of lightning damage to electrical equipment have only affected the lightning discharge through the television antenna. Then, the lightning waves were introduced through the low voltage lines into the building and damage to the electrical equipment inside the building was investigated [1]. But there are now other ways to access lightning strikes that threaten devices such as computers and other sensitive electronic communications, and thus our information society [2]. The lightning wave penetrates the buildings mainly through power lines, telecommunication lines, antennas, and conductors. Lightning wave

countermeasures for equipment, including the potential for use and protection against lightning waves, can be prevented and greatly reduced by damaging them in accordance with specific rules and regulations [2]. The main question that we face in this research is as follows:

1.1. What additional lightning strikes does the voltage generate in different parts of the building?

In order to protect the lightning and to improve the reliability and quality of the power supply, it is important to identify the mechanism that will damage the electrical equipment. The lightning wave can enter several different directions depending on the point where it discharges [3]:

- Electricity distribution lines;

* Corresponding Author: Yazdan Ashgevari
 Email: ashgevari.yazdan@gmail.com

- Telecommunication lines;
- TV antennas;
- Tree and Arrester on top of the buildings;
- The metal part of the buildings.

Many articles have discussed the lightning overvoltage in buildings low voltage lines caused by direct lightning strikes on the building antenna or overhead lines and also increases the potential of the ground from lightning striking the metal body of a building or tree close to the building over an electrical grid [4]– [8]. However, there have been few studies on the difference in overvoltage associated with different lightning strikes [9], [10]. Computer simulations are useful for investigating the effect of lightning and circuit configuration parameters in the calculation of overvoltage [11]. Complex circuits including low voltage lines can be simulated by EMTP software [12].

The simulation models for the low voltage lines are constant, so the lightning voltages for different situations can be directly compared [13]. In this paper, simulations of past article authors that have resulted from scientific and practical research on electrical equipment have been used [14]. Simulations show that in some cases the increase of the earth's potential due to lightning strikes causes the lightning to flow from the ground of a building to the distribution system and it flows to another building [15]. The results of different scenarios are also compared.

Limited scope of previous investigations: Previous studies on lightning damage to electrical equipment have primarily focused on lightning discharge through television antennas and its impact on equipment within buildings [1]. However, with the emergence of new technologies and sensitive electronic devices, there is a need to explore other pathways through which lightning strikes can pose a threat to devices, such as computers and communication systems [2]. Insufficient investigation of different lightning strike scenarios: Although some studies have discussed lightning overvoltage in low voltage lines caused by direct strikes on building antennas or overhead lines, there is a scarcity of research on the variations in overvoltage associated with different lightning strike scenarios [9, 10]. Understanding these differences is crucial for implementing appropriate lightning protection measures.

1.2. Contribution of the Paper:

Comprehensive investigation of lightning strikes: This research addresses the gap in knowledge by exploring the additional lightning strikes generated in different parts of a building. It considers various pathways through which lightning waves penetrate, such as electricity distribution lines, telecommunication lines, TV antennas, tree and arrester on top of buildings, and the metal parts of buildings. This comprehensive analysis provides valuable

insights into the diverse lightning strike scenarios that threaten electrical equipment and infrastructure. Comparative analysis of overvoltage variations: The study conducts simulations using past research models and investigates the differences in overvoltage associated with different lightning strike scenarios. By comparing and analyzing the results, the paper contributes to a deeper understanding of the factors influencing overvoltage generation, enabling the development of targeted lightning protection strategies for specific scenarios. Utilization of computer simulations: The research employs computer simulations, specifically using the EMTP software, to simulate complex circuits, including low voltage lines. This approach allows for accurate and detailed investigations into the effects of lightning and circuit parameters on overvoltage calculations. By leveraging simulation techniques, the study provides valuable quantitative data and enhances the understanding of lightning-induced overvoltage behavior.

Overall, this paper addresses the aforementioned gaps by offering a comprehensive analysis of lightning overvoltage in low voltage distribution systems. It investigates different lightning strike scenarios, conducts computer simulations, and compares the results with existing studies, providing valuable insights for the development of effective lightning protection strategies and enhancing the reliability and quality of power supply in the face of lightning-induced damage.

2. The system studied

The system studied consists of a voltage source, a three-phase series RLC branch model with a 20 kV Tevenan impedance, a 20/ 0.4 KV transformer whose zero point is driven by a ground resistance, and next to the transformer is the low voltage distribution line, which we used to simulate the inductor and resistor values of the insulators and modeling using the corresponding articles studied [16]. Designed for homes that include household electrical appliances such as TVs, washing machines, telephones, and more. The above building and network equipment has been simulated and evaluated using the Simulink section of MATLAB software.

2.1.A. Lightning wave modeling

Since the lightning is from the electric charge flowing from the clouds to the ground, in this study, the lightning impulse flow is modeled using the following representation function [17].

$$I(t) = I_m [e^{-at} - e^{-bt}] \quad (1)$$

In relation to (1):

$$I_m = 30604.79$$

$$a = 14203.84$$

$$b = 4880435$$

The IEEE standard defines the following experimental transient waveforms to determine the ability to withstand overvoltage in equipment.

This test stroke current rises to a peak value of 30 KA within 1 μ s to 1.2 μ s and decreases by half its maximum in 50 μ s (In the majority of cases, 30 or 35 kA are considered,

although other current values are reported but only one case was used to compare the effects, and it is also noteworthy that often the polarity of the lightning charge is negative, but in this paper we consider the polarity to be positive, which only affects the voltage polarity created in the simulation).

The simulated block using the relation (1) and the resulting waveform are as follows.

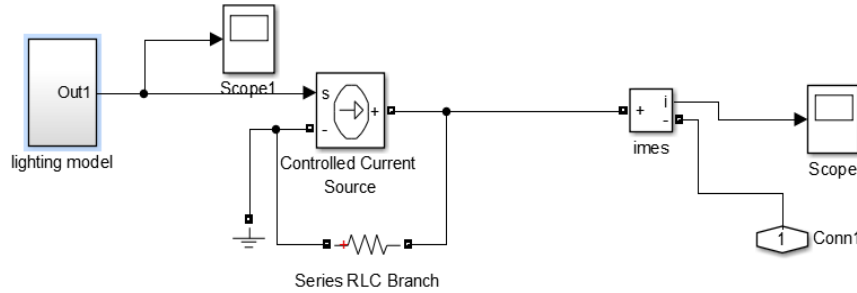

Fig. 1. Simulated block

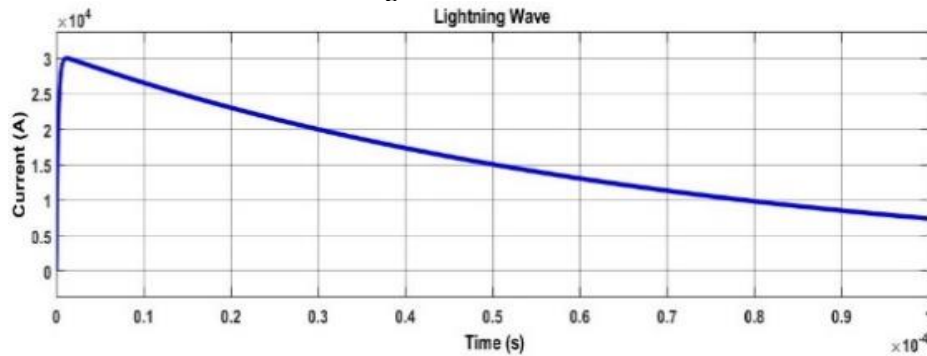

Fig. 2. Simulated impulse waveform

2.2. B. Network power supply blocks

The following block acts as an input source, which contains a programmable voltage source with a voltage level of 20 kV at a frequency of 50 Hz. In the following, we use a series resistor and inductor because the voltage source

in simulation lacks internal resistor and inductor, so the resistor and series inductor are considered as the resistor and the internal inductor of the source (The source can be assumed as an upstream network TEVENAN model).

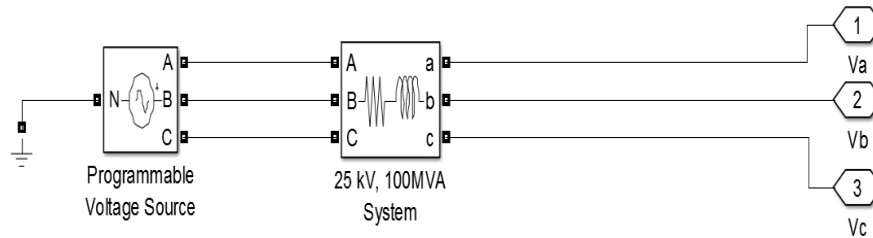

Fig. 3. Simulated source circuit in MATLAB software

2.3. C. Distribution Line Model

For the LV distribution line model, the three-phase distributed line model with the null is used because the most suitable line model for lightning waves in the transient state is the distributed model. It should be noted that in these lines the capacitance value is selected based on the wave speed (light speed for the overhead line) and the

impedance characteristic of the overhead line. The parameters not included in the simulations are the value corona and cross-inductance. The calculated voltages will be lower if they do not exclude cross-induction. The whole line is divided into five sections, each having a length of 50 meters (the length of the common low voltage line). The values of the line parameters are as follows:

Table 1. Simulated line parameters for every 50 meters

Quantity	value	unit
R	0.0005	Ohm
L	0.005	H
C	2.4E-9	F

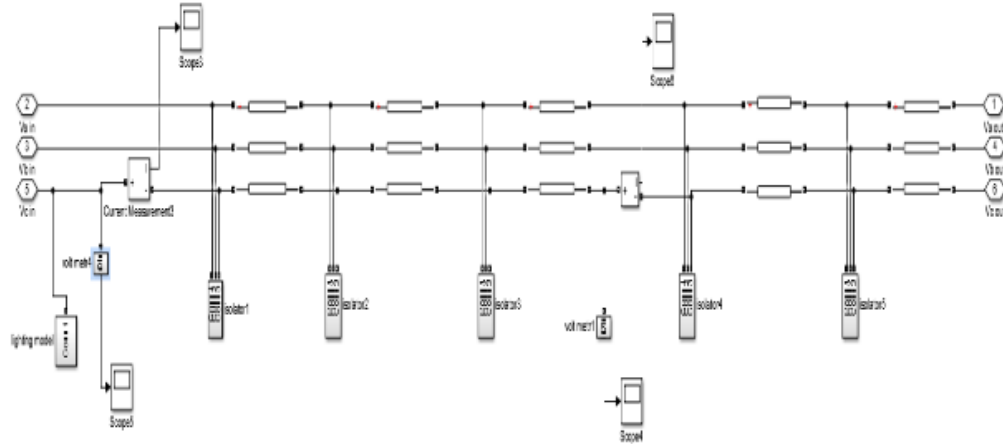

Fig. 4. Simulated source circuit in MATLAB software

2.4. D. Antenna model

According to Reference, the antenna model consists of a series RLC circuit, known as the Yagi-uda. The antenna parameters are the same for all six antennas and their values are as follows [18]:

Table 2. Yagi antenna simulation parameters

Quantity	value	unit
R	7	Ohm
L	48	nH
C	6.57	pF

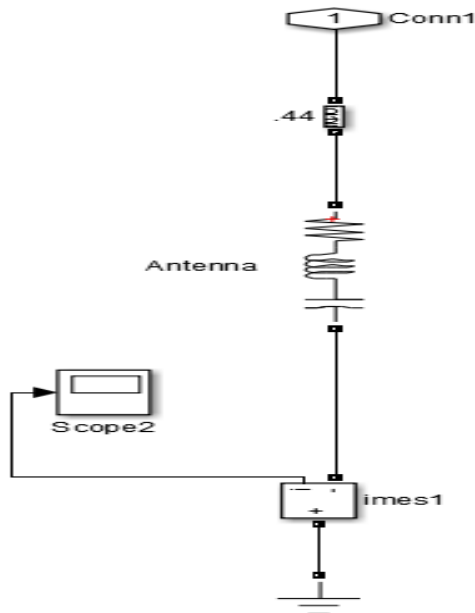

Fig. 5. Simulated circuit for antenna model in MATLAB software

2.5. E. Model of home appliances

Residential electric loads in this paper are, a washing machine, a television, and a telephone device are simulated

with reference [6] parameters and equivalent circuit. A resistor is used to model the building body.

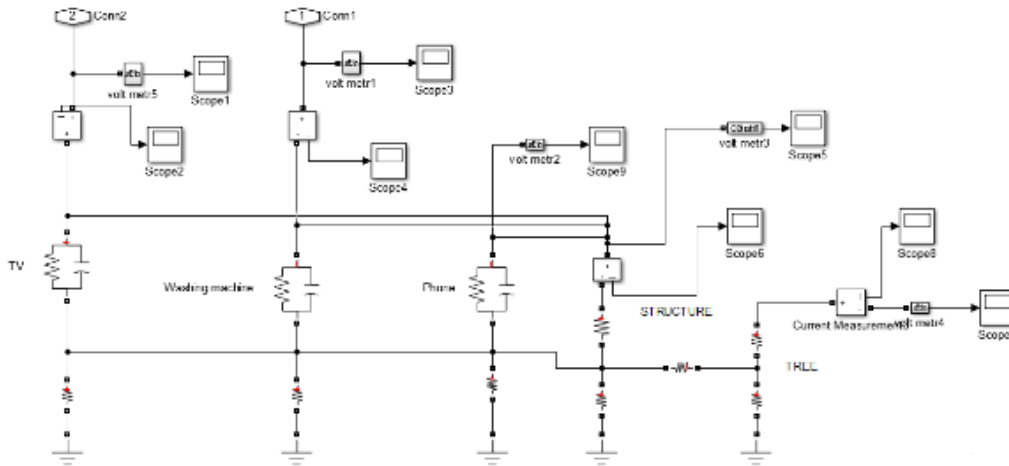

Fig. 6. Simulated circuit for a residential home in Matlab software

2.6. F. Model of Tree

The model used for the tree is a resistor, the value of which is, in laboratory conditions, 5.241 kΩ for the tree trunk and 250 kΩ for the branch [9]. Also, with the change of resistance can be used for the top of the building.

$$\frac{V}{V_{ref}} = K_i \left(\frac{I}{I_{ref}} \right)^{\frac{1}{a_i}} \quad (2)$$

2.7. G. Low Voltage Arrester Model (SPD)

For the phase-connected Arrester, the Surge Arrester block in the MATLAB software library was used. The Surge Arrester block implements a very nonlinear resistor used to protect equipment against overvoltage (SPD is currently used on building boards). The nonlinear V-I characteristic of each electrostatic column is modeled by a combination of three functions:

The protection voltage obtained is determined by a column in a reference current (usually 500 A or 1 kA). The default parameters k and a presented in the Simulink box are in accordance with the characteristic V-I provided by the main metal-oxide electrode manufacturer and do not change with the voltage of protection. The required protection voltage is obtained by adding zinc oxide disconnectors in series to each column. This characteristic V-I is shown in Fig. 8 (linear and logarithmic).

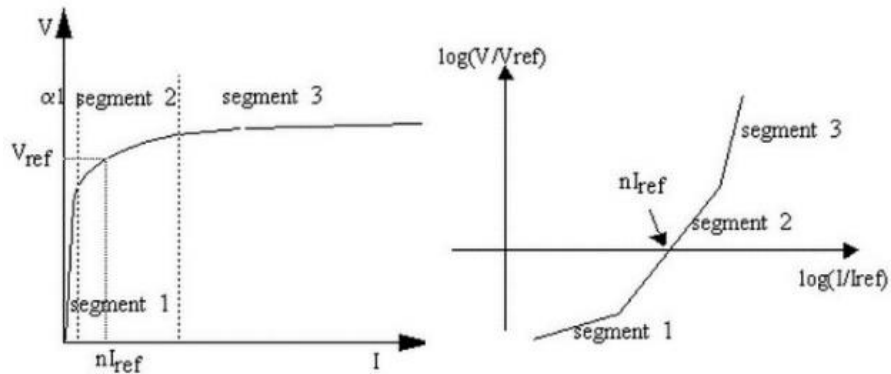

Fig. 7. Characteristics of V-I power supply

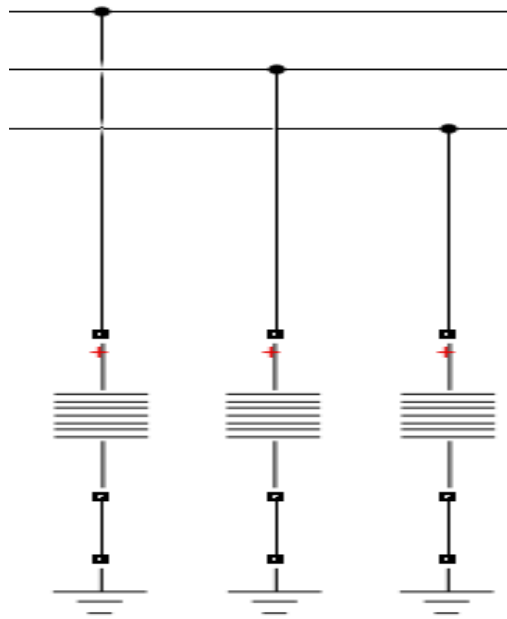

Fig. 8. SPD model

2.8. H. General Simulation Models In this article

In this simulation, two residential houses are considered for each phase of the network with the above-

mentioned simulations, which are assumed to be comparable in some scenarios a residential home for each phase.

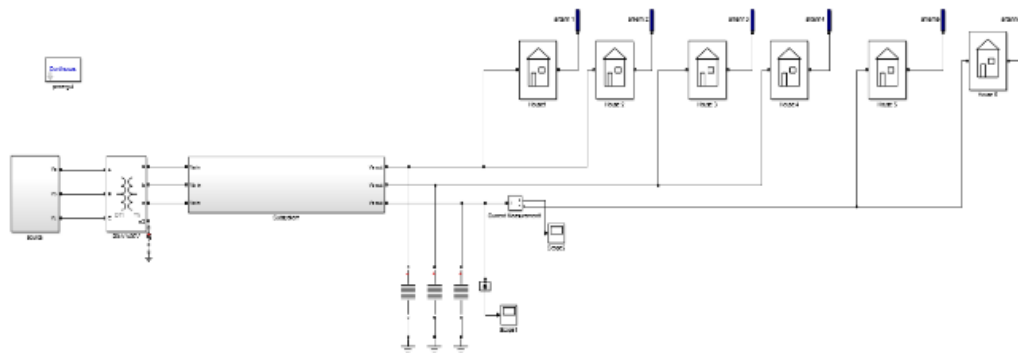

Fig. 9. Simulated overall circuit

3. Analysis of results

A. Lightning Impulse on Distribution Line When Transformer and Source are not in Circuit

This is rarely case in the network. It can be seen in Fig. 11 that if the capacitance of LV lines, though very low, is not

ignored, Wave reversals also occur in low-voltage networks. The presence of inductors and capacitors in different parts of the circuit causes the shock waves to oscillate in stairs. Resistance in LV lines, LV insulators, and side loads has caused the shock wave amplitude to decrease.

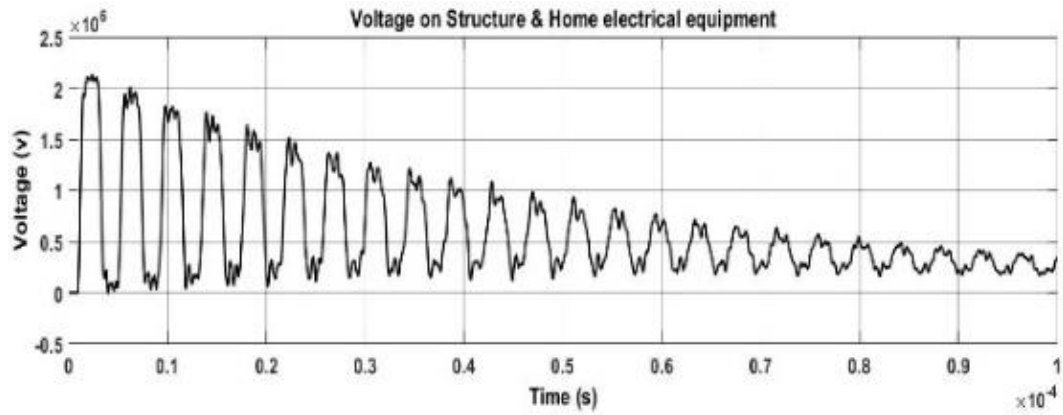

Fig. 10. Voltage waveform on the building equipment and structure when the lightning strikes near the transformer

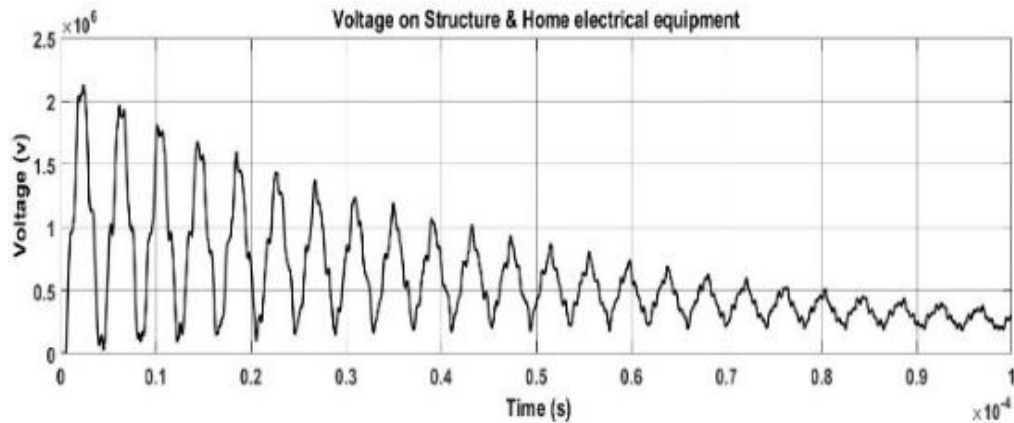

Fig. 11. Voltage waveform on building equipment and structure when lightning strikes middle of the line

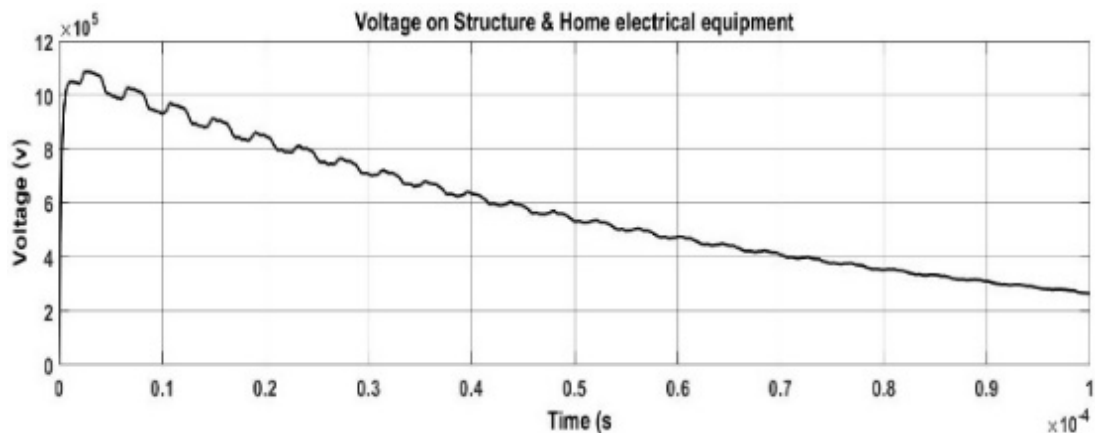

Fig. 12. Voltage waveform on building equipment and structure when lightning strikes near the loads

According to the waveforms obtained in three different states, it is observed that when the lightning strikes the beginning and the middle of the line, a higher voltage (2.5×10^6 v) is observed than the lightning stroke at the end of the line (12×10^5 v). The reason for the high voltage seen with the discharge point being far from the load is the doubling of the voltage in the shock wave impedance to the relatively high load impedance against

the specified impedance of the line. It should be noted that when the lightning strikes the middle of the line, the discharged electricity is divided into two parts and moves from that point to the two sides of the line, resulting from the integration of the two waves above. But the lightning strike at the end of the line and near the buildings largely follows the simulated lightning wave pattern, because the source, which is the lightning current, is at the point of

charge (the Norton model), and unlike the two previous states where the lightning wave has an oscillation amplitude, the amplitude of its oscillations is less.

B. Lightning strike the distribution line while the transformer and the source are in network

Another simulation is the one that usually happens, because a transformer and source Tevenan are in distribution network. In this case, lightning is applied to different locations and the shape of the output waves is examined.

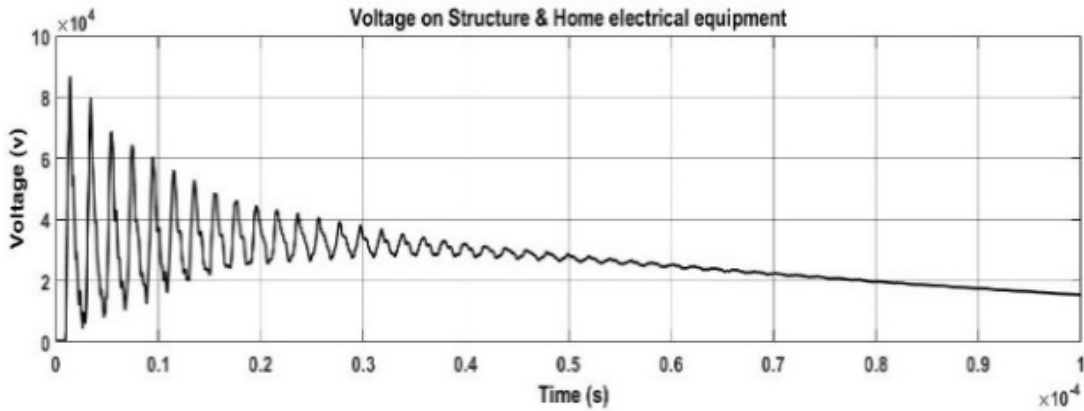

Fig. 13. Voltage waveform on building equipment and structure when lightning strikes near the loads

According to the waveforms obtained in three different states, it is observed that when the lightning strikes the beginning and the middle of the line, a higher voltage (2.5×10^6 v) is observed than the lightning stroke at the end of the line (12×10^5 v). Creates. The reason for the high voltage seen with the discharge point being far from the load is the doubling of the voltage in the shock wave impedance to the relatively high load impedance against the specified impedance of the line. It should be noted that when the lightning strikes the middle of the line, the discharged electricity is divided into two parts and moves from that point to the two sides of the line, resulting from the integration of the two waves above. But the lightning

strike at the end of the line and near the buildings largely follows the simulated lightning wave pattern, because the source, which is the lightning current, is at the point of charge (the Norton model), and unlike the two previous states where the lightning wave has an oscillation amplitude, the amplitude of its oscillations is less.

B. Lightning strike the distribution line while the transformer and the source are in network

Another simulation is the one that usually happens, because a transformer and source Tevenan are in distribution network. In this case, lightning is applied to different locations and the shape of the output waves is examined.

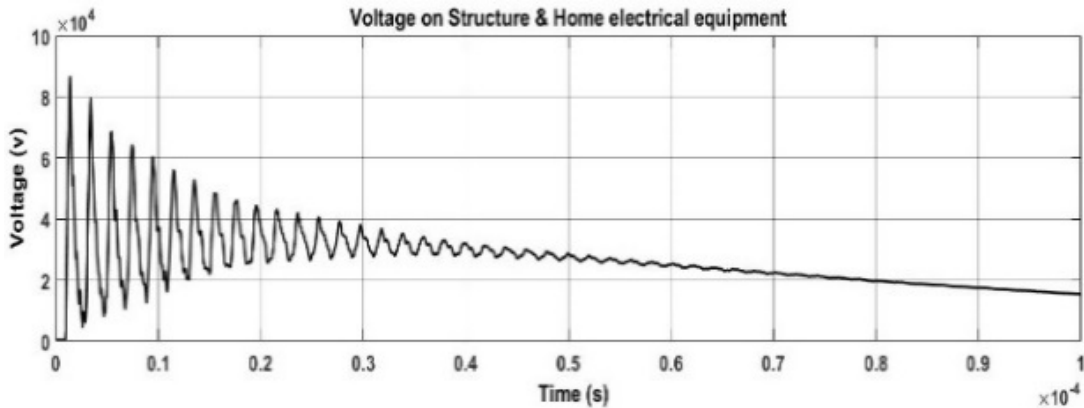

Fig. 14. Voltage waveform on building equipment when lightning strikes at the transformer side

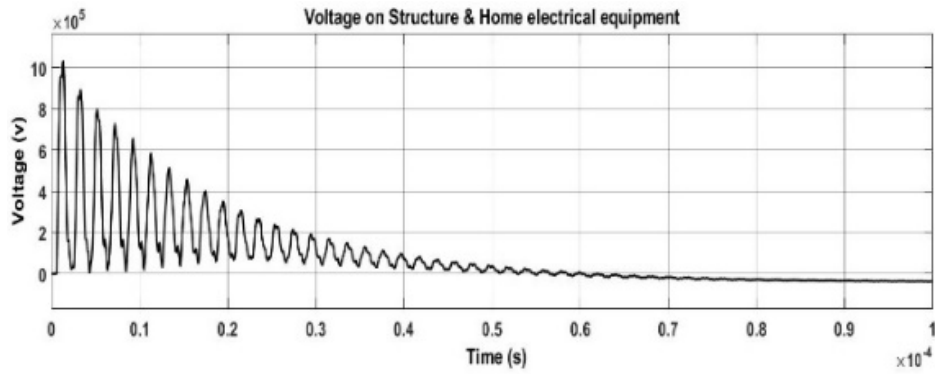

Fig. 15. Voltage waveform on building equipment when lightning strikes middle of the line

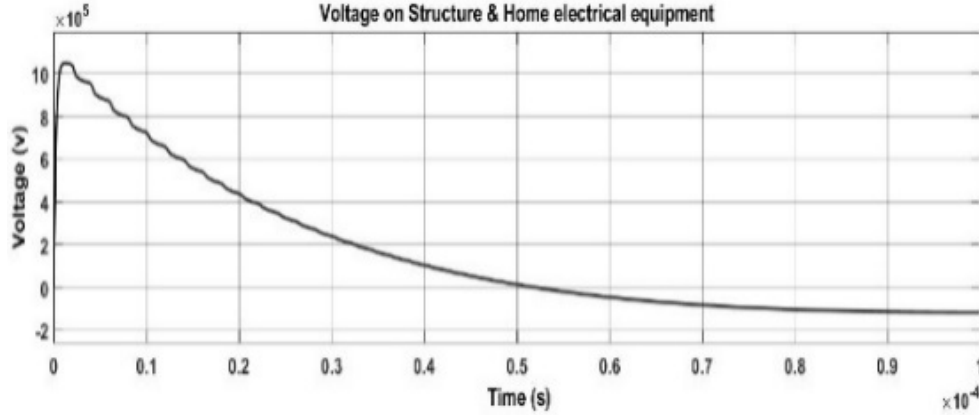

Fig. 16. Voltage waveform on building equipment when lightning strikes near the loads

In this case, the overvoltage is at its highest when the lightning discharge at the middle and end of the line (10×10^5 v). As in the previous case, when the lightning strikes the end of the line, the waveform seen on the home equipment is similar to the simulated waveform for the lightning and has less fluctuation than the lightning stroke at the beginning and middle of the line. As can be seen, in this case the damping of the waves is higher than the previous state (transformer is open). When the lightning strikes the transformer side, there are three paths to the

discharged lightning charge: null of transformer, source-side Tevenan path, and LV line, thereby reducing the charge, leading to the side of the line. The existence of several resistors in parallel in the circuit reduces the power of the wave. (It should be noted that the transformers in the network act as open circuits for shock waves, but in simulating this software it transfer the shock waves to the other side).

C. Lightning Strikes on Distribution Line While Transformer in Circuit and Source is out of Circuit

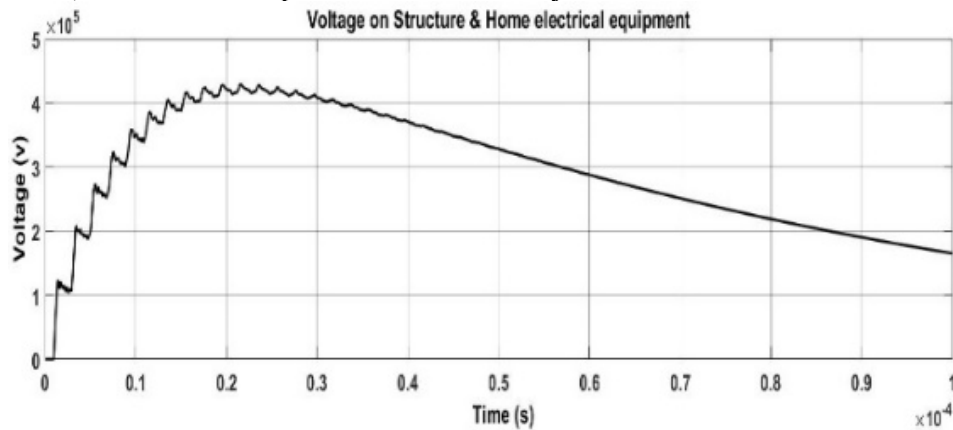

Fig. 17. Voltage waveform on building equipment and structure when lightning strikes near the transformer

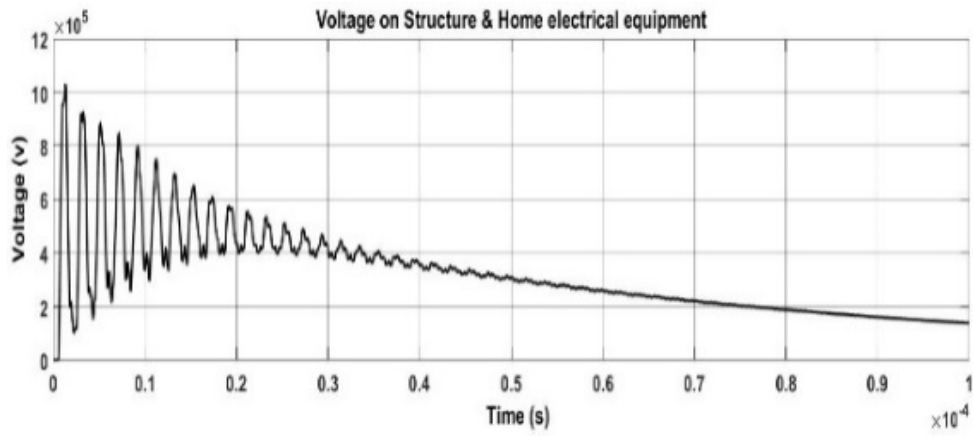

Fig. 18. Voltage waveform on building equipment and structure when lightning strikes middle of the line

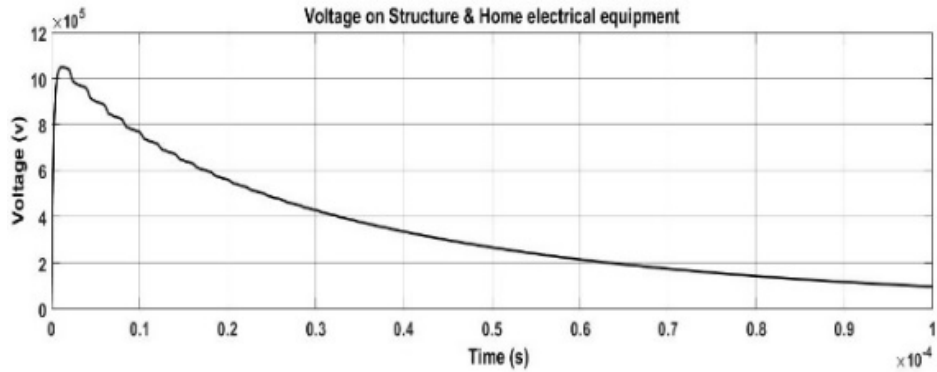

Fig. 19. Voltage waveform on building equipment and structure when lightning strikes near the loads

From the comparison of Figures 18, 17 and 19, it can be seen that the peak voltage when lightning discharges the middle and near the loads ($10.5 \times 10^5 \text{ v}$) is greater than when the lightning strikes transformer side ($5 \times 10^5 \text{ v}$),

but their difference is less than before. When the lightning discharges on the transformer side, the existence of the transformer coils causes the waveform Figure (17).

D. Direct lightning strike to the antenna

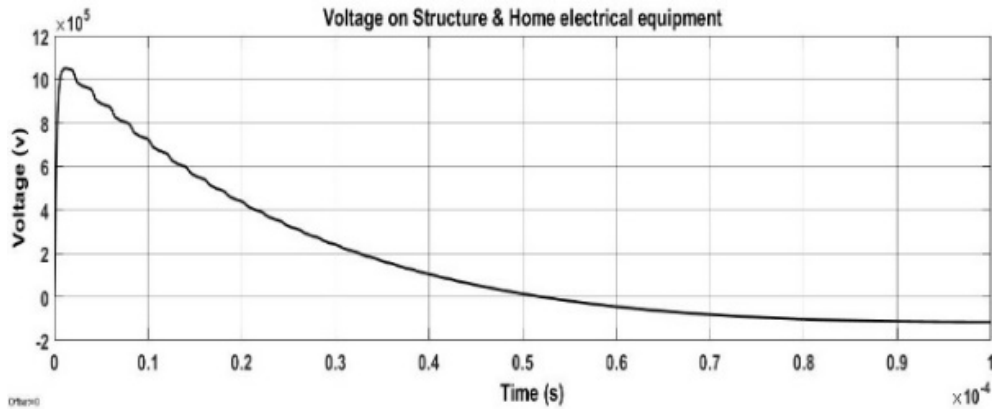

Fig. 20. Voltage waveform on building equipment and structure when lightning strikes antenna

The lightning strikes to the antenna of the overvoltage generates approximately ($10.5 \times 10^5 \text{ v}$) on the home equipment and its structure which approximately equals the overvoltage caused by the lightning strikes on the

distribution line. This is due to the appearance of overvoltage on the insulation of the device similar to the lightning strike of the phase conductor.

E. Lightning strikes a tree

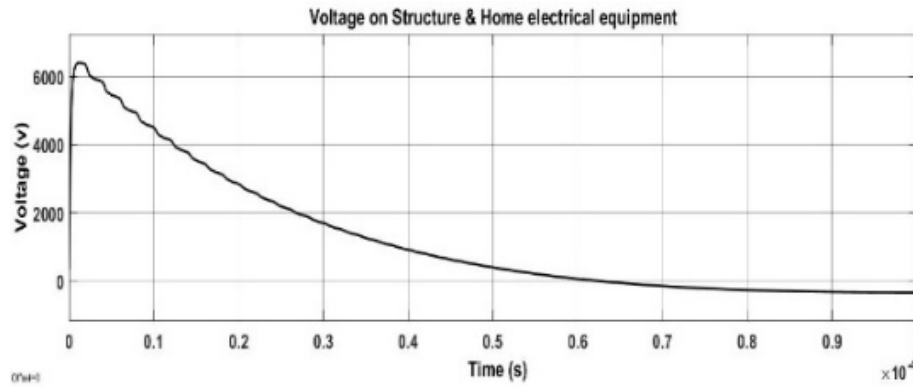

Fig. 21. Voltage waveforms on building equipment and structure when lightning strikes a tree

Lightning strikes a tree near a residential home, generating an overvoltage of about 6 kV, which is lower than other lightning strikes. This voltage decreases with increasing distance of the tree from the building. The reason for this decrease is the resistance to drainage, but it is still a threat to the electronic equipment in the building, which should try to incorporate appropriate protective equipment to prevent damage.

F. Variation of Null Transient Point Resistance and strikes on the Phase Wires of the Load, Tree and Antenna

The voltage distribution study was performed on the electrical equipment of residential homes by changing the resistance null of the low-voltage transformer. There was no significant change in the shape and size of the voltage wave in this study.

G. Comparison of one house and two houses in each phase and strikes on the load side

The LV network has the highest number of consumer divisions. Therefore, it is necessary to study the wave behavior for states where the number of consumers (home load) changes.

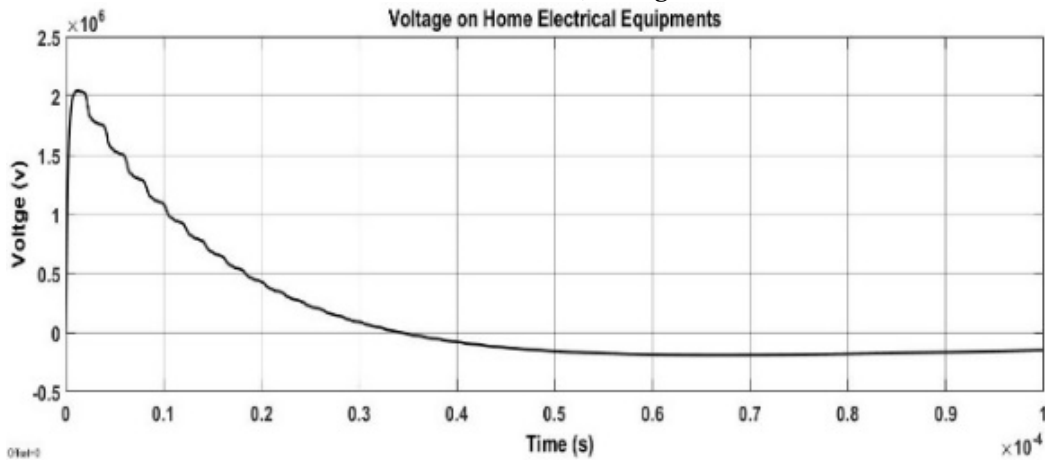

Fig. 22. Voltage waveform on building equipment when lightning strikes end of line and there is a house on each phase

From the above figure, it can be concluded that the greater the number of subscribers by connecting the separate ground at the point of lightning discharge, the less the excess voltage appearing. Because the evacuation routes to the ground are increasing. In this figure, the voltage is approximately twice the voltage shown in Figure 16.

H. Lightning strikes on the null wire of the load

Low-voltage network coverage is longer and wider than other networks. But in most cities, low-voltage networks are cable and underground, and if it is overhead, they are in favor of buildings. But in some small towns and villages there are overhead networks, and for some reason they place the null wire on top of the other wires in the network, which are more likely to strike lightning.

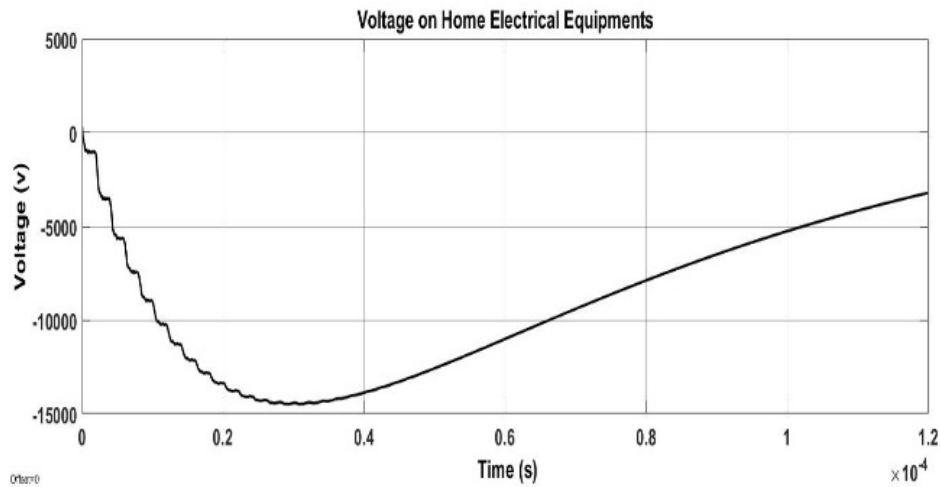

Fig. 23. Voltage waveform on building equipment when lightning strikes on null wire near the load

It is seen in the above simulated figure that if the lightning strikes the null wire, it causes an inverse voltage surge on the building equipment.

I. Monitor the wave behavior of the phase wire by using SPD in the network

The following model is used to investigate the simulation at this stage.

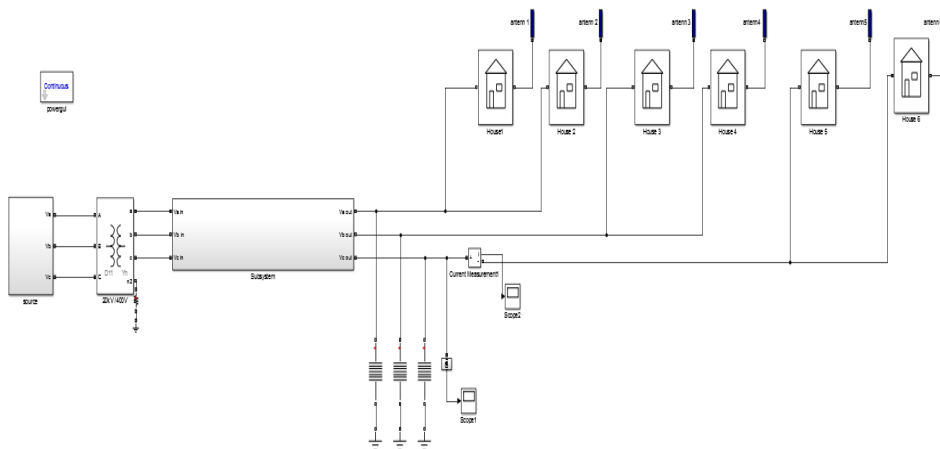

Fig. 24. Model used to simulate the SPD effect on the network

The absence of Surge Protective Devices (SPDs) in low voltage (LV) networks, including distribution systems, is indeed a common practice in many countries. In these scenarios, distribution companies typically focus on employing arresters solely on the high-voltage side of transformers, while neglecting the LV side. There are several reasons behind this prevailing approach. One primary consideration is the cost-benefit analysis associated with implementing SPDs. SPDs can add significant costs to the installation and maintenance of LV networks, including the need for periodic inspections and potential replacement of the devices. This cost factor often leads to the exclusion of SPDs in LV networks, as the perceived benefits of surge protection may not outweigh the

associated expenses. Furthermore, there may be a lack of awareness or understanding regarding the potential risks of lightning-induced overvoltage in LV networks. Many distribution companies prioritize the protection of high-voltage equipment and infrastructure, assuming that the LV side is less susceptible to lightning-related damages. This perception might stem from the belief that the primary lightning strike targets are taller structures or objects, such as transmission towers, rather than LV distribution lines. Additionally, the absence of specific regulations or standards mandating the use of SPDs in LV networks contributes to their limited adoption. In the absence of regulatory requirements, distribution companies may prioritize investments in other areas of network

maintenance and upgrades. However, it is crucial to recognize the potential consequences of not employing SPDs in LV networks. Lightning-induced overvoltage can still propagate from the high-voltage side to the LV side of transformers, posing risks to sensitive equipment and

electronics within buildings or connected to LV lines. Without proper surge protection, these devices may experience damage, downtime, or even complete failure due to overvoltage events.

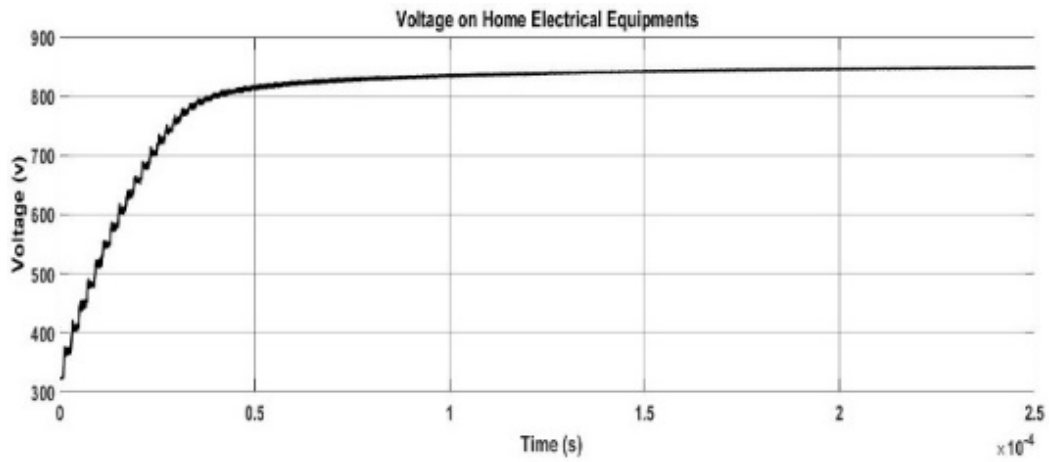

Fig. 25. Voltage waveform on building equipment when lightning strikes near the transformer on the phase wire

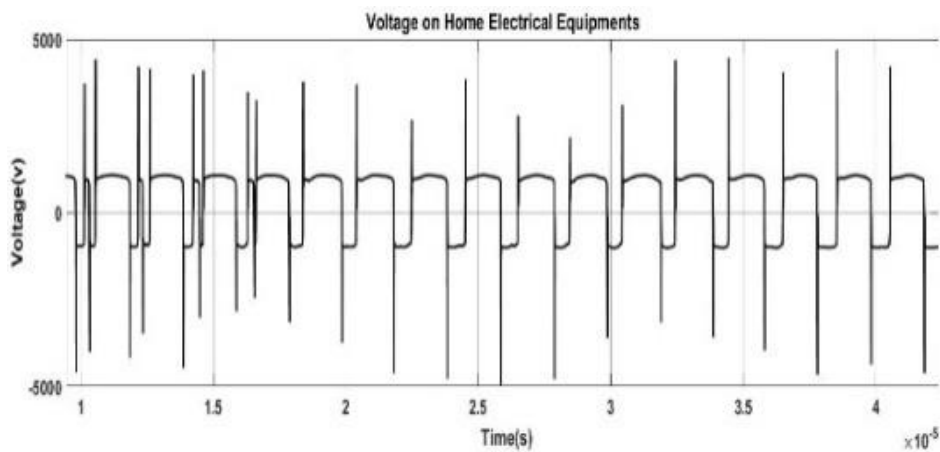

Fig. 26. Voltage waveform on building equipment when lightning strikes middle line on phase wire

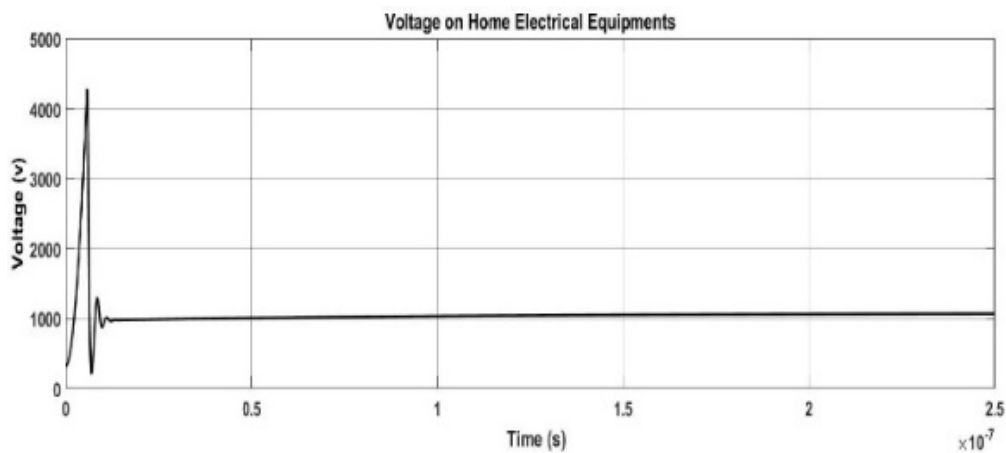

Fig. 27. Voltage waveform on building equipment when lightning strikes near the load on phase wire

The above figures show that if there is a SPD near the lightning strike point, the overvoltage is low (lightning strikes at the beginning and end of the line). But if there is no SPD lightning impact point, the overvoltage can be seen as positive and negative pulses on the equipment (lightning stroke in the middle of the line).

4. Conclusion

The most dangerous form of overvoltage is caused by atmospheric discharge on the antenna, as it provides a direct path for the discharge to travel through the antenna equipment and reach the ground. To mitigate this risk, lightning rods are installed on building rooftops to prevent lightning strikes on the antenna. However, when atmospheric discharge strikes the phase conductor of the distribution line and no Surge Protective Device (SPD) is employed on the grid, equipment becomes vulnerable to overvoltage. The number of loads per branch (path to ground) inversely affects the magnitude of overvoltage, with a higher load count resulting in lower overvoltage levels. Nevertheless, the best approach is to use SPDs in conjunction with the loads, including those installed alongside transformers. However, if atmospheric discharge occurs on the wires themselves, the building's structure, or if the neutral wires are not properly grounded at various points along their path, it can lead to reverse voltage surges on the building's equipment. Although the magnitude of this voltage is relatively low, it can still cause damage to sensitive equipment. One crucial aspect of this simulation is the transfer of impulses to the other side of the simulated transformer within MATLAB, while ensuring that the other side has a ring to allow current passage. Transformers, by nature, behave as open circuits due to their inductor components (coils and cores) and should not allow the passage of the impulse wave. It is important to note that in global distribution networks, particularly in TN-C systems, appropriate grounding is employed at specific positions along the neutral wire. The aforementioned simulation could serve as a valuable study for further understanding and analysis of distribution networks.

Overall, by focusing on the development of advanced surge protection technologies, optimizing their placement and configuration, and integrating intelligent monitoring and control systems, future research has the potential to significantly enhance the protection of electrical equipment from lightning-induced overvoltage. These advancements would contribute to the overall resilience, reliability, and safety of electrical systems in the face of lightning threats.

REFERENCES

- [1] A. Ahmadpour, E. Mokaramian, and S. Anderson, "The effects of the renewable energies penetration on the surplus welfare under energy policy," *Renew Energy*, vol. 164, pp. 1171–1182, 2021.
- [2] I. Hetita, A. S. Zalhaf, D.-E. A. Mansour, Y. Han, P. Yang, and C. Wang, "Modeling and protection of photovoltaic systems during lightning strikes: A review," *Renew Energy*, vol. 184, pp. 134–148, 2022.
- [3] A. Dejamkhooy and A. Ahmadpour, "Torque ripple reduction of the position sensor-less switched reluctance motors applied in the electrical vehicles," *Journal of Operation and Automation in Power Engineering*, vol. 11, no. 4, pp. 258–267, 2023.
- [4] V. Radulović and Z. Miljanić, "Determination of Effective Protection Distance in Front of Surge Protective Devices in Low Voltage Systems," in *Advanced Technologies, Systems, and Applications IV-Proceedings of the International Symposium on Innovative and Interdisciplinary Applications of Advanced Technologies (IAT 2019)*, Springer, 2020, pp. 74–90.
- [5] Z. Kasza and K. Kovacs, "Risk analysis about lightning protection for buildings focusing on risk of loss of human life," *Procedia Manuf*, vol. 32, pp. 458–465, 2019.
- [6] M. Paolone, F. Rachidi-Haeri, and C. A. Nucci, "IEEE guide for improving the lightning performance of electric power overhead distribution lines," IEEE, 2010.
- [7] A. Sultan, "Comparative Study between Porcelain and Silicone Polymer Lightning Arresters under Direct Lightning Strokes for A 400KV Substation Protection," in *Libyan International Conference on Electrical Engineering and Technology (LICEET 2018)*, pp. 60–65.
- [8] Y. Zhang, H. Chen, and Y. Du, "Lightning protection design of solar photovoltaic systems: Methodology and guidelines," *Electric Power Systems Research*, vol. 174, p. 105877, 2019.
- [9] G. Maslowski and S. Wyderka, "Modeling of currents and voltages in the lightning protection system of a residential building and an attached overhead power line," *IEEE Trans Electromagn Compat*, vol. 62, no. 5, pp. 2164–2173, 2020.
- [10] A. Dejamkhooy and A. Ahmadpour, "Optimal UC and economic dispatching with various small energy resources in the micro-grid using IPPOA and IMILP," *Energy Reports*, vol. 7, pp. 7572–7590, 2021.
- [11] A. I. Ioannidis, P. N. Mikropoulos, T. E. Tsovilis, and N. D. Kokkinos, "A fractal-based approach to lightning protection of historical buildings and monuments: The Parthenon case study," *IEEE Industry Applications Magazine*, vol. 28, no. 4, pp.

20–28, 2022.

- [12] N. A. Sabiha, M. Alsharif, M. K. Metwaly, E. E. Elattar, I. B. M. Taha, and A. M. Abd-Elhady, “Sustaining electrification service from photovoltaic power plants during backflow lightning overvoltages,” *Electric Power Systems Research*, vol. 186, p. 106386, 2020.
- [13] Z. Zhao, S. Wang, and Y. Cui, “Research on Protection Performance of Surge Protective Devices against Electromagnetic Pulse,” *Appl Bionics Biomech*, vol. 2022, 2022.
- [14] H. Chen, Y. Zhang, Y. Du, and Q. S. Cheng, “Lightning transient analysis of telecommunication system with a tubular tower,” *IEEE access*, vol. 6, pp. 60088–60099, 2018.
- [15] N. S. Piro, A. S. Mohammed, and S. M. Hamad, “Multiple analytical models to evaluate the impact of carbon nanotubes on the electrical resistivity and compressive strength of the cement paste,” *Sustainability*, vol. 13, no. 22, p. 12544, 2021.
- [16] D. K. Shahi, H. B. Rijal, and M. Shukuya, “A study on household energy-use patterns in rural, semi-urban and urban areas of Nepal based on field survey,” *Energy Build*, vol. 223, p. 110095, 2020.
- [17] G. Maslowski and S. Wyderka, “Modeling of currents and voltages in the lightning protection system of a residential building and an attached overhead power line,” *IEEE Trans Electromagn Compat*, vol. 62, no. 5, pp. 2164–2173, 2020.
- [18] E. Mokaramian, H. Shayeghi, F. Sedaghati, A. Safari, and H. H. Alhelou, “An optimal energy hub management integrated EVs and RES based on three-stage model considering various uncertainties,” *IEEE Access*, vol. 10, pp. 17349–17365, 2022.