



Advanced in Engineering and Intelligence Systems

Journal Web Page: <https://aeis.bilijipub.com>



Temperature Estimation of Smart Homes with Sensors in Internet of Things Environment based on Block Chain

Jie Yuan^{1,*}, Kim Hung Pho²

¹School of Information Engineering, Minzu University of China, Beijing 100081, China

²Faculty of Mathematics and Statistics, Ton Duc Thang University, Ho Chi Minh City, Vietnam

Highlights

- Smart homes are one of the most promising communications protocols
- Block chain-based model is used for temperature estimation of smart homes
- The proposed PID controller is a three-part controller that includes proportional, integral, and derivative parts
- The fuzzy logic controller is used to improve the PID controller parameters
- The proposed approach has a better result in terms of the temperature estimation and control

Article Info

Received: 12 November 2022
Received in revised: 27 March 2023
Accepted: 28 January 2023
Available online: 28 March 2023

Keywords

Smart Homes,
Internet of Things (IoT),
6LoWPAN Protocol,
Z-WAVE Protocol,
Fuzzy-PID-HTC Controller,
Block Chain

Abstract

Today, smart homes are used as one of the most promising communications protocols technologies. The combination of these protocols for communicating with the Internet of Things can carry a remote control. There are a variety of challenges in smart homes one of them is temperature estimation to check green energy consumption. This study tries to use the Internet of Things to estimate the temperature of smart homes, which combines and integrates Z-WAVE into smart homes and 6LoWPAN communication protocols on the Internet of Things. A processor environment has been created as the central base using a blockchain for optimally adapting the ambient temperature of the environment based on a robust controller, which is used in the PID-HTC controller structure of the blockchain to control the temperature accurately. Obtained results show an improvement over the previous method.

1. Introduction

The With the widespread use of the Internet and mobile network technologies, the term "smart home" has been introduced. In general, an intelligent building is one that has a strong communications infrastructure and can respond to the changing environment, adapt to it, and allow the inhabitants to do the same, allowing available resources to be used more efficiently and residents' safety and security to be enhanced. Today, in an intelligent house, it is not important to spend on controlling electric consumption, but in addition to optimum management and

control of costs, the convenience of using and integrating control components is an important point in home automation [1]. The home management system is a collection of software and hardware designed to monitor and control the various components of the building for optimal use of resources (energy, appliances, and equipment). It provides more comfort and creates a safe and desirable environment [2]. All intelligent home appliances are designed and built on the X10's two-way technology, which gives the user the power to check the status in addition to issuing commands. This means that a

* Corresponding Author: Jie Yuan:
Email: yuan.jie@muc.edu.cn

user can obtain information about the power on or off for each electrical appliance, the opening or closing of a curtain, and the remote control of a telephone system. This device can be used for buildings that are wired or not controlled by four advanced remote-control methods, including control by phone or keyboard, Internet control, and traditional control (the so-called common method using single brush keys and two bridges) [3].

The Internet of Things is aimed at increasing communication. The Internet in today's world is available as a means of human-to-human communication, but the Internet of Things intends to import tools and machines in this regard. This goal also leads to the formation of human communication with a device, which increases the number of communications, and as a result, a large amount of data will be generated by tools and machines. The Internet of Things is a computational concept for describing the future in which physical objects connect to the Internet one by one and interact with other objects. The Internet of Things has a close relationship with the concept of radio frequency identification as a communication method but also includes sensor technologies, wireless technologies, quick response codes, and so on. It has a layered architecture; first, there is a perceptual layer in which information is received from the physical world. In the next step, information is transmitted over the network. Finally, information is applied to the application layer. It should be noted that each of the steps has its own technology. The application layer does not help in the creation of the Internet of objects; it is end-user hosting that uses the information received from the Internet of objects. As a result, focusing on the technologies that require the Internet of Things focuses on two layers: perception and network. The first technology refers to those that receive information that is perceived as a layer [4].

A robust thermal and electrical management of smart homes based on information gap decision theory (IGDT) has been proposed based on [5]. The proposed IGDT-based performance optimization problem of the low-energy smart home was formulated as mixed-integer non-linear programming (MINLP) and solved by General Algebraic Modeling System (GAMS) optimization software. The energy consumption was estimated at 22 joules. Temperature forecasts with stable accuracy in a smart home were proposed in [6] as a challenge. A variety of sensors were used based on a dataset with time criteria to simulate energy consumption and temperature estimation. Selecting sensors when forecasting temperature in smart buildings is proposed in [7]. The minimal error occurred with nine sensors, such as Wi, Tw, TL, TD, T, SW, SE, CL, and CD. RMSE was used as the main evaluation criterion. In another study, which is presented in [8] and can be

considered a similar approach to its forthcoming research, fuzzy logic was used as a controller for lighting brightness in smart homes. The proposed controller resulted in the setting of light levels in the environment and automatic adjustment. Another goal was to reduce light and total energy consumption during peak consumption periods while taking into account the intensity of lighting in the environment. The energy consumption was 32 joules. Another study outlined in [9] was to provide a centralized lighting control system for smart homes, the main purpose of which was to overcome the problems of inaccurate and timely control. The use of the Internet of Things in these sensors and the proposed controller, as a means of establishing communication and monitoring the system, is considered a new approach for 2012–2014. Providing a supervisory and automatic monitoring system for intelligent home lighting control is one of the main goals of this research. The energy consumption was 34 joules. In [10], an approach called NFC was used to control lighting in smart homes. This method used sensors that were based on the brightness of the environment based on color variations at the RGB level and were also sensitive to movements. The user could set up a set of settings at the beginning of the system purchase and apply them at any time. This structure took into account the decision based on the user's settings and the brightness of the environment. The energy consumption of this method is 32.24 joules. A remote monitoring system based on structural management systems was provided in [11]. In fact, structural management systems provided new ways of controlling and monitoring smart home environments in order to optimize and simplify their use. One of the main uses and objectives of this CO₂ detection research was to reduce costs and energy consumption in sensors in a variety of environments. The energy consumption was 34.21 joules.

One of the main uses of the Internet of Things in smart homes is temperature estimation and control, which is possible with sensor installation. For this purpose, it is necessary to install the sensor and connect it with the peripheral device connected via the Internet. The sensors have a series of controllers that connect to each other through the Internet. Due to the uncertainty that exists in these systems, the use of fuzzy logic alongside the PID controller seems necessary. It will be possible to use a reliable Fuzzy-PID controller with an HTC controller. In fact, this research addresses the problem of network structure in smart homes and creates both a monitoring system and a controllable structure. The prime goals of this research are to provide remote control of the smart home temperature system using the Internet of Things as well as

to reduce energy consumption. The contribution of this paper is as follows:

1. The simultaneous design of a reliable Fuzzy-PID controller with an HTC controller to provide remote control of the smart home temperature system using the Internet of Things
2. Creating a platform to reduce energy consumption as an important parameter in smart homes

The remainder of this paper is organized as follows: In section 2, the proposed method is introduced and reviewed. In Section 3, the overall model of the system is first shown. Then the desired structure is simulated, and the results are discussed. Section 4 also contains the conclusion and a general report of the design and simulation results.

Table 1. Nomenclature

Abbreviations			
		W_n	total number of bits that the node sends at time t
PID	Proportional–Integral–Derivative	$m(n, t)$	chosen path in the time interval t by the node n
IOT	Internet of Things	N on $Col_{m(t)}$	Bernoulli random variable
RGB	Red, Green, Blue	$h(t)$	humidity rate of the air
RMSE	Root-Mean-Square Error	$G_c(s)$	PID controller conversion function
IGDT	Information Gap Decision Theory	K_p	proportional gain
GAMS	General Algebraic Modeling System	K_I	integral gain
MINLP	Mixed-Integer Non-Linear Programming	K_D	Derivative gain
FIS	Fuzzy Interface System	$r(k)$	system input
AES	Advanced Encryption Standard		
NFC	Near Field Communication	$y(k)$	system output
6LoWPAN	IPv6 over Low-Power Wireless Personal Area Networks	$e(k)$	system error
HTC	Home Temperature Control	$, k_i$ and $k_D k_p$	PID controller coefficients
Parameters and Constants			
		N^j	fuzzy period of the law j
PFI_{ij}	packet guidance index	$x(t)$	system state vector
N_s^{ij}	number of packets properly guided by the next step node j in the object's Internet environment	$u(t)$	inference of the output of the fuzzy controller
N_t^{ij}	total number of packets driven from nodes i to the next step j in the object's Internet environment	$\mu_{N^j}(x(t))$	membership functions
PFI_{path}	tracking path index		

2. Proposed Method

The proposed method consists of several sections taken separately. In the first step, the simulation model of an Internet of Things in the smart home (in an enclosed system) based on blockchain is discussed. In the second step, the fuzzy controller PID is created to control the simulated model. The reason for using a fuzzy controller is the uncertainty in the control parameters of temperature estimation and control systems. The use of block chain

technology is also being provided for the long-term accuracy of temperature estimation and the proper management of the energy sector. The purpose of this research is to manage and reduce energy consumption and save it, along with improving temperature estimation and control. Z-WAVE and 6LoWPAN are considered the main communication protocols between sensors and devices.

2.1. Modeling of Temperature Estimation of Smart Homes with Internet of Things

The temperature estimation model in smart homes on the Internet of Things serves a single thermal zone. The packet guidance index occurs when information is received through sensors that are to be controlled by objects in the Internet environment. It is expressed as Eq (1).

$$PFI_{IJ} = \frac{1}{p_f^{ij}} \quad (1)$$

The PFI term is the same as the lead index. Given the relation (1), the value of p_f^{ij} is obtained from Eq (2).

$$p_f^{ij} = \frac{N_s^{ij}}{N_t^{ij}} \quad (2)$$

According to equation (2), N_s^{ij} is the number of packets properly guided by the next step node j in the object's Internet environment, and N_t^{ij} is the total number of packets driven from nodes i to the next step j in the object's Internet environment. Now, using this relationship, each node gains the package guidance for nodes in its next step, and calculates the tracking path index according to Eq (3).

$$PFI_{path} = \log(10 \times PFI_{i,i+1}) + \log(10 \times PFI_{i+1,i+2}) + \log(10 \times PFI_{i+2,i+3}) \quad (3)$$

Each node calculates the packet guidance index after calculating the packet guidance, and then the path that has the best index to guide the data packets is chosen from the ones provided by the node in the next step. An Internet of Things with several nodes whose set of paths is $Route_{set} = \{1, \dots, M\}$ along with the bandwidth of the path as $m \in Route_{set}$ and is taken as a unit of Hz. Meanwhile, the use of a system with a specified time interval is $t \in \{1, \dots, t\}$ in each interval. Knots need to be routed for sensitivity and resource efficiency. At the end of each time period, the receiver sends a message to the sender for a successful transfer operation. When the nodes are more than one in the system, the set of nodes will be $Node = \{1, \dots, N\}$. The path m with probability θ_m is considered as a free path and with probability $1 - \theta_m$ as a busy path. Considering a random Bernoulli variable in the form $\zeta_{m(t)}$, it is determined that if it is equal to one, then the path m is free at time t and if it is zero, then other states will occur. It should be noted that the nodes in the Internet environment of objects are not aware of the vector path of the entity as $\theta = (\theta_1, \dots, \theta_m)$ and $C_m(t)$ is a collection of nodes that select the path m in the time interval t they pay. After capturing the path spectrum, it is possible to send B bits in the path

of m at time t . In this case, there may be three events that describe the Eqs (4) and (5).

$$\text{if } \zeta_{m(t)} = 1 \quad |C_m(t)| \leq 1 \quad (4)$$

$$\text{if } \zeta_{m(t)} = 0 \quad |C_m(t)| > 1 \quad (5)$$

If equation (4) holds, the node waits until the path and efficiency of the spectrum up to the next round, and if Eq (5) is established, the nodes will overlap with the other nodes and there will be no nodes. The bandwidth of the selected route cannot be used over time. The total number of bits that the node sends at time t is calculated as (6).

$$W_n = \sum_{t=1}^T B \cdot \zeta_{m(n,t)}(t) \cdot NonCol_{m(t)}(t) \quad (6)$$

According to Eq (6), $m(n, t)$ is the chosen path in the time interval t by the node n . $NonCol_{m(t)}$ is also a Bernoulli random variable, which if it is equal to one, there will be no overlap between nodes and if it is equal to zero, then another operation is performed. The goal is to maximize the transmission of data through sensors by relation (7).

$$W = \sum_{t=1}^T W_n = \sum_{n=1}^N \sum_{t=1}^T B \cdot \zeta_{m(n,t)}(t) \cdot NonCol_{m(t)}(t) \quad (7)$$

Connection from route i to route j may occur during time interval and cost c . The total cost of route connections is calculated by adding a number of intervals when each node connects from one path to another in the time interval T . It should be noted that the purpose of the node is the same as the sensors of the temperature estimation system, and the purpose of the path is in fact the path to which the connection with the controller is established. All components of the temperature estimation system are considered as energy balance equations. For this proposed model, two control loops, including the heat control loop and the control loop, consider the moisture content. The set of arbitrary points in heat and humidity is based on a system controller that simultaneously maintains the difference for f_{sa} and f_{sw} to change the load. Variables are named in the naming. Differential equations for the energy-based system for detecting energy-based temperature estimation system and mass balance equations are defined in Eq (8) to (10).

$$c_{ah} \frac{dT_{co}}{dt} = f_{sw} p_w c_{pw} (T_{wi} - T_{wo}) + (UA)_a (T_o - T_{co}) \quad (8)$$

$$+ f_{sa} p_a c_{pa} (T_m - T_{co})$$

$$c_h \frac{dT_h}{dt} = f_{sa} c_{pa} (T_{si} - T_h) + \alpha_h (T_o - T_h) \quad (9)$$

$$v_h \frac{dw_h}{dt} = f_{sa} (w_{si} - w_h) + \frac{h(t)}{p_a} \quad (10)$$

According to Eq. (8), the energy change rate in the air flow from the coil is equal to the energy added by the flow rate of the heating coil, and the energy is transmitted by the return air to the enclosure. In Eq (10), $h(t)$ is the humidity rate of the air where and also a function of the moisture content. The form of the space of the state of the system of recognition of temperature as a differential equation is based on the relations (8) to (10) in the form of relations (11) to (14).

$$x_1 = g_{11}(x).u_1 + g_{21}(x).u_2 \quad (11)$$

$$x_2 = g_{12}(x).u_1 \quad (12)$$

$$x_3 = f_3(x) + g_{13}(x).u_1 \quad (13)$$

$$x = \begin{bmatrix} 0 \\ 0 \\ f_3(x) \end{bmatrix} + \begin{bmatrix} g_{11}(x) \\ g_{12}(x) \\ g_{13}(x) \end{bmatrix} u_1 \quad (14)$$

$$+ \begin{bmatrix} g_{21}(x) \\ 0 \\ 0 \end{bmatrix} u_2, \quad \begin{cases} y_1 = h_1(x) = x_1 \\ y_2 = h_2(x) = x_3 \end{cases}$$

2.2. Fuzzy-PID-HTC Controller

The PID controller is a controller based on the output feedback. This controller is one of the most commonly used control systems. In the proposed structure, a PID controller along with the operator and evaluator of the proposed model for the temperature estimation system is used. The PID controller conversion function is given by (15).

$$G_c(s) = K_p + \frac{K_1}{s} + K_D s \quad (15)$$

With respect to Eq (15), K_p is proportional gain, K_1 is integral gain and K_D is a derivative, which are in fact the same parameters of the PID controller. The physical examination of this controller is possible by an electrical circuit. In order to control the temperature estimation system, the PID is used as a compensator along with a fuzzy-based control technique. The reason for using the fuzzy method is because of the uncertainty surrounding

temperature detection system when the PID controller is used. The derived derivative of the output is represented by (16) and (17).

$$e(k) = r(k) - y(k) \quad (16)$$

$$u(t) = k_p [e(t) + k_i \int_0^t e(t) dt + k_d \frac{de(t)}{dt}] \quad (17)$$

According to Eq (16) and (17), $r(k)$ is the reference system input, $y(k)$ is the system output and $e(k)$ is the system error. Also k_p , k_i and k_d are PID controller coefficients. To regulate extraction laws of k_p , k_i and k_d descending gradient methods are applied to the chain rule to minimize the performance index function. The incremental PID controller algorithm is defined as Eq (18) to (21).

$$\Delta k_p = -\mu \frac{\partial E}{\partial k_p} = -\mu \frac{\partial E}{\partial y} \cdot \frac{\partial y}{\partial u} \cdot \frac{\partial u}{\partial k_p} = \mu e(k) \cdot \frac{\partial y}{\partial u} \cdot e_p(k) \quad (18)$$

$$\Delta k_i = -\mu \frac{\partial E}{\partial k_i} = -\mu \frac{\partial E}{\partial y} \cdot \frac{\partial y}{\partial u} \cdot \frac{\partial u}{\partial k_i} = \mu e(k) \cdot \frac{\partial y}{\partial u} \cdot e_i(k) \quad (19)$$

$$\Delta k_d = -\mu \frac{\partial E}{\partial k_d} = -\mu \frac{\partial E}{\partial y} \cdot \frac{\partial y}{\partial u} \cdot \frac{\partial u}{\partial k_d} = \mu e(k) \cdot \frac{\partial y}{\partial u} \cdot e_d(k) \quad (20)$$

$$u(k) = u(k-1) + k_p \cdot e_p(k) + k_i \cdot e_i(k) + k_d \cdot e_d(k) \quad (21)$$

In order to uncertainty in the PID controller in temperature estimation system due to different temperature conditions in the identification of thermal, it is necessary to use a controller that can guarantee this uncertainty. Therefore, the fuzzy controller is used. Four-phase fuzzy controller has been used to improve the parameters of the PID controller. j 'th law is given by Eq (22).

$$\text{Rule } j: \text{ If } x(t) \text{ is } N^j \text{ Then } u(t) = G_j x(t) \quad (22)$$

According to equation (22), N^j , the fuzzy period of the law j corresponds to the system state vector $x(t)$, $j = 1, 2, 3, 4$; $G_j \in \mathbb{R}^{1 \times 4}$ is the law j for the collector feedback vector. The inference of the output of the fuzzy controller is given by (23).

$$u(t) = \sum_{j=1}^4 m_j(x(t)) G_j x(t) \quad (23)$$

According to equation (23), the equation (24) and (25), the nonlinear function of the vector $x(t)$ and $\mu_{N^j}(x(t))$, $j = 1, 2, 3, 4$ membership functions that should be designed and HTC used for reliability optimization.

$$\sum_{j=1}^4 m_j(x(t)) = 1 \quad (24)$$

$$HTC_{m_j}(x(t)) = \frac{\mu_{Nj}(x(t))}{\sum_{k=1}^4 \mu_{Nj}(x(t))} \quad \text{for } j = 1,2,3,4 \quad (25)$$

It should be noted that the reliable fuzzy controller does not require $m_j(x(t)) \in [0 \ 1]$ for all j states.

2.3. Block Chain Structure

The block chains are like a database, similar to an entire office, in which data is stored and encrypted in batches. Using the hash functions, these data can be stored at the database level, which is necessary to increase security in this block chain. The block chain is a decentralized storage system for information. In this system, all data with the AES algorithm is encrypted in 256 bits, and data is split into different blocks, each block being decrypted by the key

obtained from the previous block. But this key is not qualified to open a block. Simply put, each block is created by irreversible mathematical equations. Block chains may become the primary method for storing data chains sooner than current projections suggest. One of the most important benefits of the block chain is the use of intelligent contracts. The block chain is available and acts as a management and monitoring tool for smart home temperature after applying the controller; it is also applied to the proposed system and can be seen in the simulation phase.

3. Simulation and Results

First, the overall model of the system is shown. This model also has two sub-models in common, each with a common PID controller. The generalized model presented in Fig. 1.

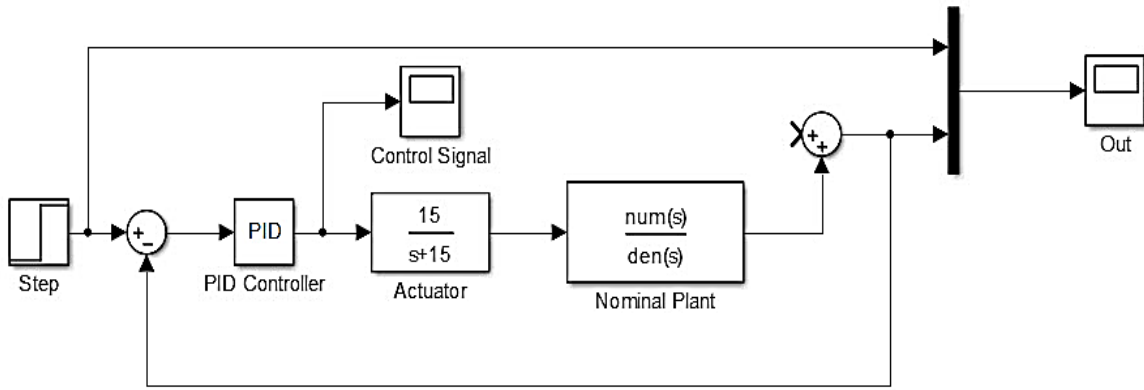

Fig. 1. The proposed model of temperature estimation system and control system

A fuzzy PID controller is required to be used for this purpose from the FIS toolbox in MATLAB. The fuzzy PID controller system is of the Mamdani type and has two inputs, including energy (e) and heat (ec). It also has an

output that is used to set the thermal in the smart home for the temperature estimation system, which is called u. The fuzzy PID controller system is shown in Fig. 2.

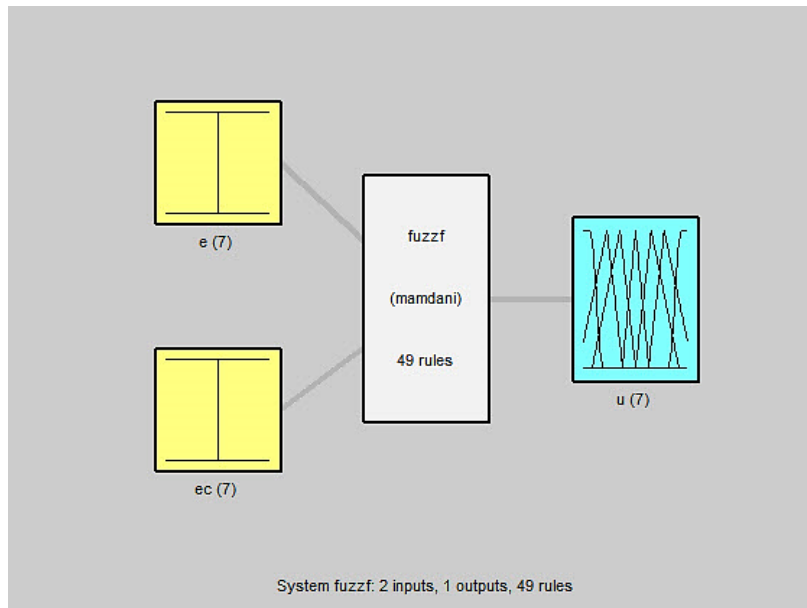

Fig. 2. The proposed model of temperature estimation system and control system

In a fuzzy system, it is necessary to determine the linguistic variables and membership functions for input and output, which, according to the PID controller structure, has its fuzzy mode for two inputs, including energy and heat (Fig. 3), which determines the language

variables and functions of the entry of energy. Fig. 4 shows linguistic variables and the inputs of heat, and Fig. 5 shows linguistic variables and the functions of the output of thermal adjustment in smart homes for the temperature estimation system.

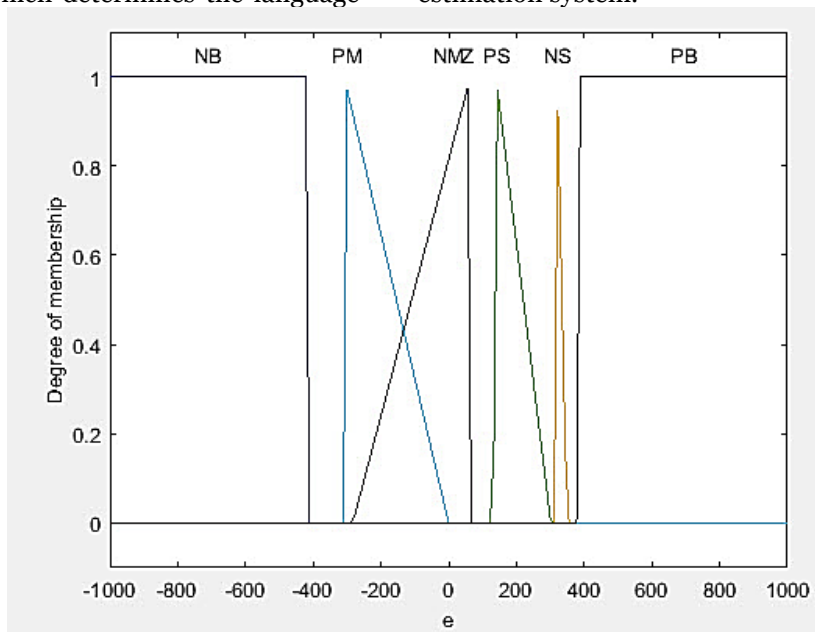

Fig. 3. Linguistic variables and energy input membership Function

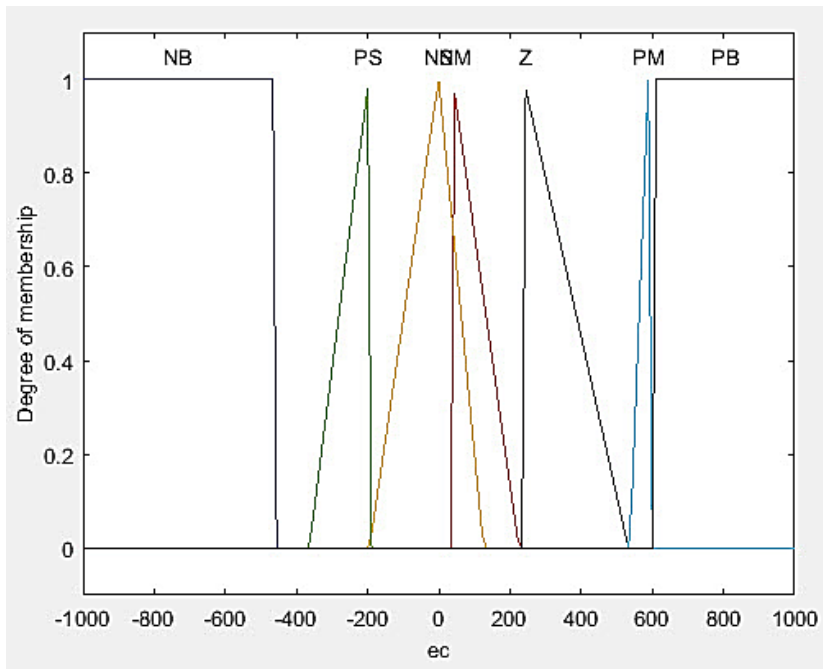

Fig. 4. Linguistic variables and heat input membership Function

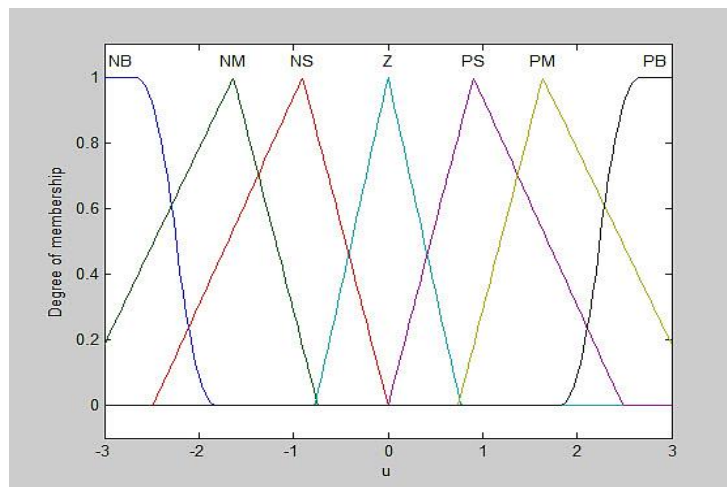

Fig. 5. Linguistic variables and functions for the inclusion of thermal output in smart homes for the temperature estimation system

Each fuzzy system requires a set of rules for the connection between input and output that are formed between linguistic variables and membership functions. To

achieve fuzzy control of the PID control, 49 fuzzy rules are used, which are similar to Fig. 6.

1. If (e is NB) and (ec is NB) then (u is NB) (1)	17. If (e is NS) and (ec is NS) then (u is NS) (1)	33. If (e is PS) and (ec is PS) then (u is PS) (1)
2. If (e is NB) and (ec is NM) then (u is NB) (1)	18. If (e is NS) and (ec is Z) then (u is NS) (1)	34. If (e is PS) and (ec is PM) then (u is PM) (1)
3. If (e is NB) and (ec is NS) then (u is NM) (1)	19. If (e is NS) and (ec is PS) then (u is Z) (1)	35. If (e is PS) and (ec is PB) then (u is PM) (1)
4. If (e is NB) and (ec is Z) then (u is NM) (1)	20. If (e is NS) and (ec is PM) then (u is PS) (1)	36. If (e is PM) and (ec is NB) then (u is NS) (1)
5. If (e is NB) and (ec is PS) then (u is NS) (1)	21. If (e is NS) and (ec is PB) then (u is PS) (1)	37. If (e is PM) and (ec is NM) then (u is Z) (1)
6. If (e is NB) and (ec is PM) then (u is NS) (1)	22. If (e is Z) and (ec is NB) then (u is NM) (1)	38. If (e is PM) and (ec is NS) then (u is PS) (1)
7. If (e is NB) and (ec is PB) then (u is Z) (1)	23. If (e is Z) and (ec is NM) then (u is NS) (1)	39. If (e is PM) and (ec is Z) then (u is PS) (1)
8. If (e is NM) and (ec is NB) then (u is NB) (1)	24. If (e is Z) and (ec is NS) then (u is NS) (1)	40. If (e is PM) and (ec is PS) then (u is PM) (1)
9. If (e is NM) and (ec is NS) then (u is NM) (1)	25. If (e is Z) and (ec is Z) then (u is Z) (1)	41. If (e is PM) and (ec is PM) then (u is PM) (1)
10. If (e is NM) and (ec is NS) then (u is NM) (1)	26. If (e is Z) and (ec is PS) then (u is PS) (1)	42. If (e is PM) and (ec is PB) then (u is PB) (1)
11. If (e is NM) and (ec is Z) then (u is NS) (1)	27. If (e is Z) and (ec is PM) then (u is PS) (1)	43. If (e is PB) and (ec is NB) then (u is Z) (1)
12. If (e is NM) and (ec is PS) then (u is NS) (1)	28. If (e is Z) and (ec is PB) then (u is PM) (1)	44. If (e is PB) and (ec is NM) then (u is PS) (1)
13. If (e is NM) and (ec is PM) then (u is Z) (1)	29. If (e is PS) and (ec is NB) then (u is NS) (1)	45. If (e is PB) and (ec is NS) then (u is PS) (1)
14. If (e is NM) and (ec is PB) then (u is PS) (1)	30. If (e is PS) and (ec is NM) then (u is NS) (1)	46. If (e is PB) and (ec is Z) then (u is PM) (1)
15. If (e is NS) and (ec is NB) then (u is NM) (1)	31. If (e is PS) and (ec is NS) then (u is Z) (1)	47. If (e is PB) and (ec is PS) then (u is PM) (1)
16. If (e is NS) and (ec is NM) then (u is NM) (1)	32. If (e is PS) and (ec is Z) then (u is PS) (1)	48. If (e is PB) and (ec is PM) then (u is PB) (1)
		49. If (e is PB) and (ec is PB) then (u is PB) (1)

Fig. 6. Fuzzy rules for Fuzzy PID controller

Also, each fuzzy system, after applying the fuzzy rules, has a level that is for the fuzzy PID controller in Fig. 7.

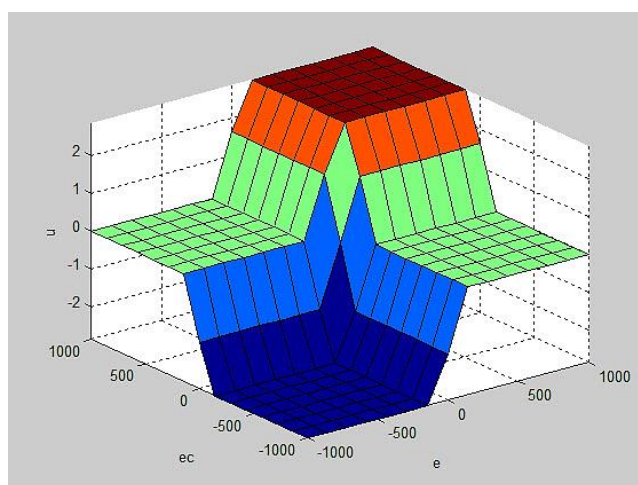

Fig. 7. Fuzzy PID surface

The Internet of Things with a control processor embedded in itself is referred to the main model of the temperature estimation system in a smart home based on the Internet environment of objects. That is, when an encoding file is executed, an optimization for the controller

and its resistant type is shown, and ultimately the overall results of optimized energy and optimal stability are also shown. First, you need to run the fuzzy part of the PID. The result is equation (9).

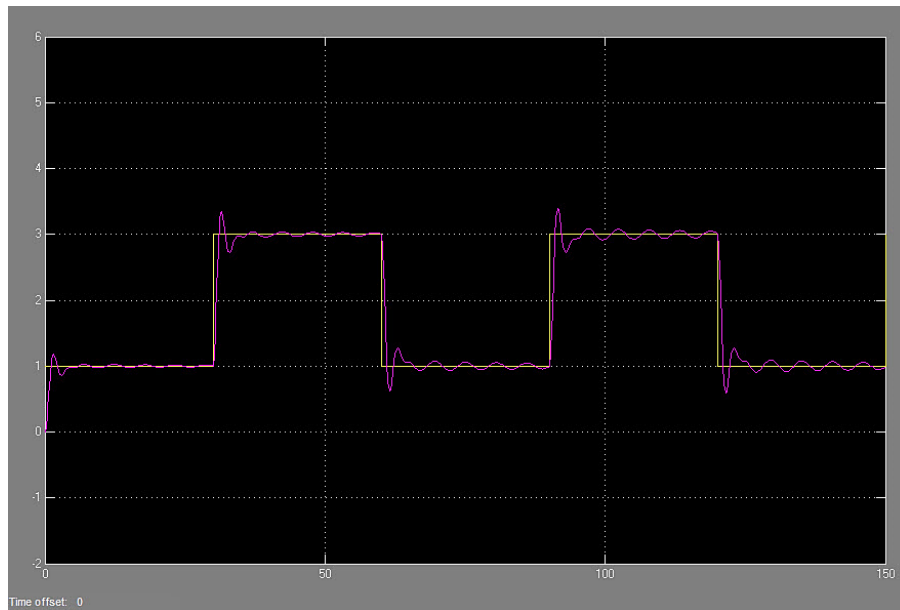

Fig. 8. Fuzzy PID controller result

As it is known, the result of the PID controller shown in violet color is noise. After using fuzzy logic, the stack has been lost. The rest of the state after the use of the block

chains is also added to this controller. The result is shown in Fig. 9.

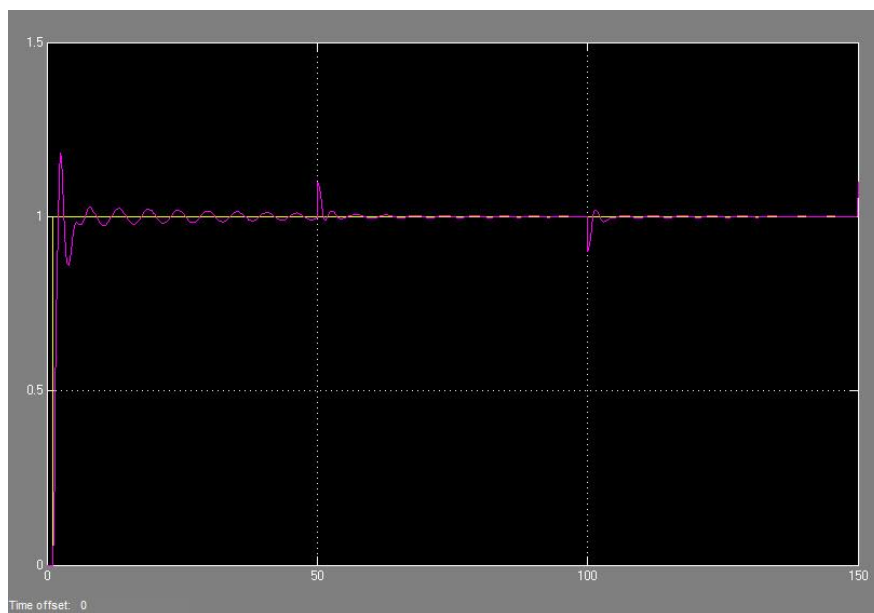

Fig. 9. result of fuzzy PID controller with the block chain's reliability

Fig. 9. shows the violet diagram that means the use of the PID fuzzy controller does not have high resistance, and there are noises in different parts. However, when the block chain is used and added to the fuzzy PID controller, the result shows a non-noise resistant state with yellow color.

In general, the reference model of the temperature estimation system is executed, which is the result of the figure (11). In this figure, the Internet of Things is implemented as the control of the controller components, namely the fuzzy PID and the blockchains.

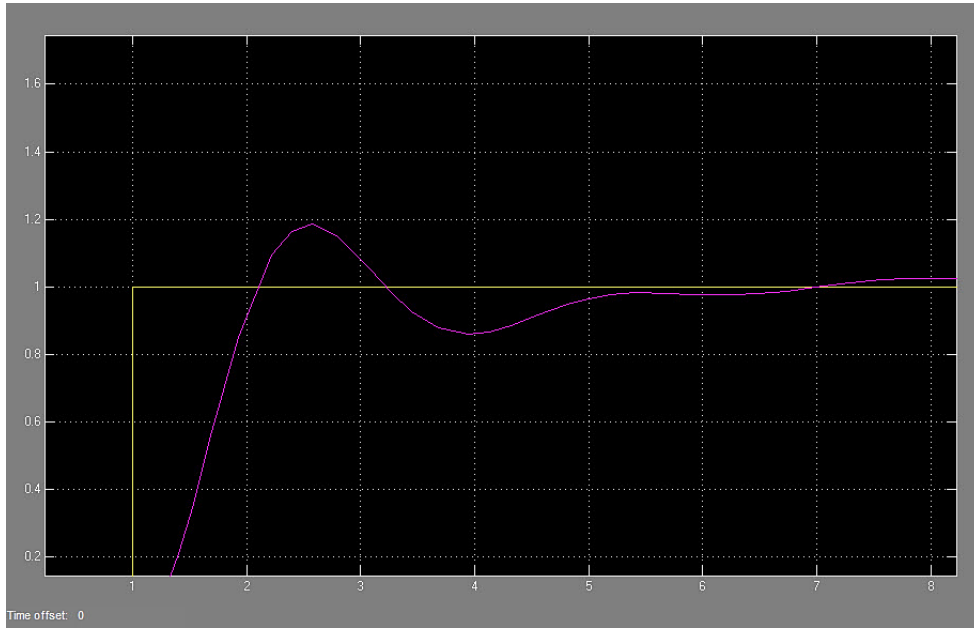

Fig. 10. The result of the reference model of the temperature estimation system after applying the Internet of Things to the controller

According to Fig. 10, as is shown by taking into account the Internet of Things, the control parameters (yellow diagram) improve, and as a result there is not any noise.

The x-axis is based on the time interval. Figure 11 also shows the output signal after applying the proposed general method.

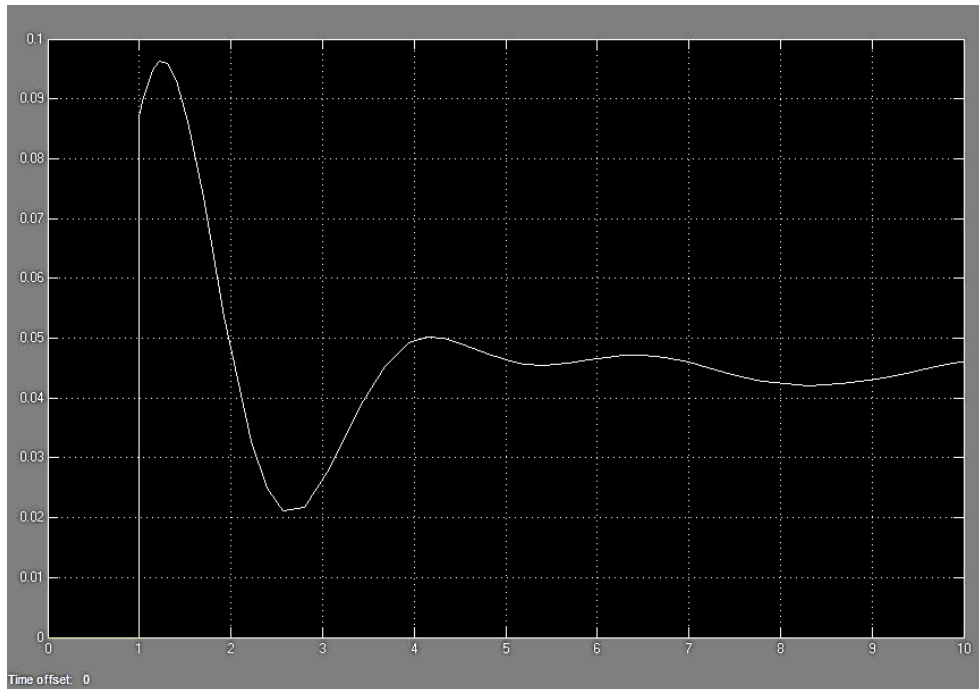

Fig. 11. Output signal of proposed method

According to Fig. 11, the x-axis is based on the time interval. To optimize energy and sustainability, the Internet of Things is applied to the proposed controller. The result

is the optimized energy consumption of the temperature estimation system as shown in Fig. 12.

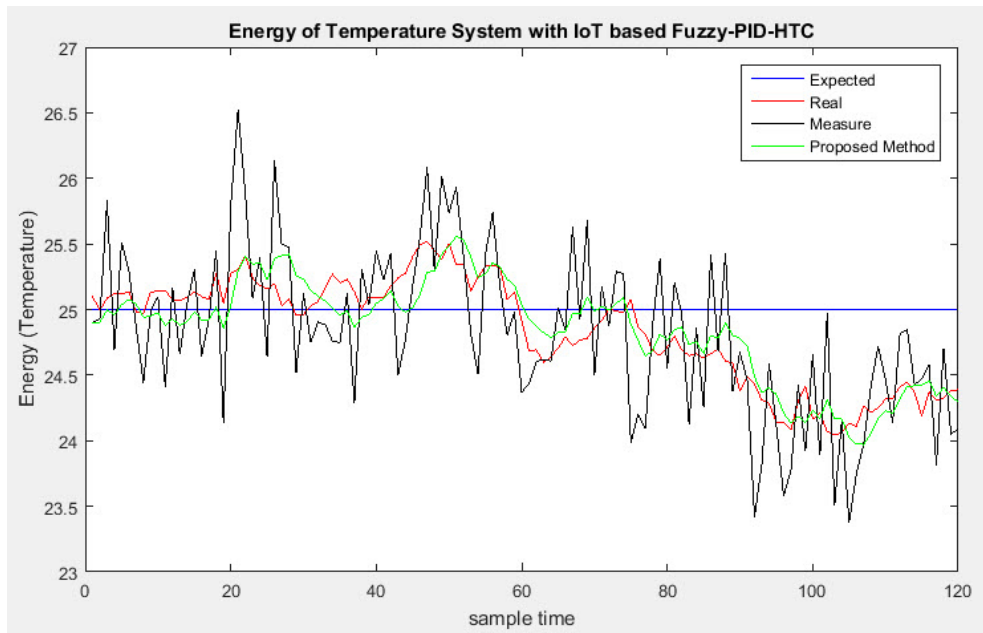

Fig. 12. Optimized energy of temperature estimation system

The object's Internet environment is coded with its controllers and, as a script, at runtime, results in output Fig. 12., and the variables of its operators and its mathematical functions are placed in the Workspace window to optimize the upcoming issue, they will be called at the time of implementation of the Simulink section. The outputs of this section (Fig. 12.) are an expected model of the system. Real is the real part of this issue, Measure is the measure of this issue and the Proposed Method is based on the proposed method with the Internet approach of objects that represents the energy of the optimized temperature estimation system. In fact, the three parts of Expected, Real, and Measure are state variables. As is shown clearly in Fig. 12, the proposed method (green diagram), has less average power consumption than the actual mode of the temperature detection and control system (red color), as well as the measured energy consumption (black color). This optimization of energy consumption is based on the y-axis in terms of joule and on the x-axis in terms of repetition time and sample, which was initially set to 120 rounds. The overall energy consumption management in the smart home temperature estimation system is 25.25 Joule.

Reference articles [5-11], are the main and basic elements of this research. They also consider energy consumption as a benchmark. The energy unit considered

by them is Joule, which has used this same purpose for the same unit. In the same study, their inputs included energy and heat. In our proposed approach that led to the fuzzification of these two inputs, the fuzzy vector is considered in the range of 1000 to 1000 for both inputs. Each fuzzy input has 7 language variables and a membership function that displays different energy and heat consumption in the temperature estimation system during control with the PID controller. It should be noted that the primary controller is PID, and then the controller is fuzzy. Each part of the PID controller must have a value that includes P with a value of 0.01, I with a value of 25.1, and D with a value of 24.9. The initial temperature is also 0.01 and the threshold is 0.25. After this, the fuzzy PID controller is to be retrofitted with the blockchains. Assembling sensors in the user's centralized controller and a sensor in the lighting system structures, you can control the temperature and adjust it through the object's Internet interface. The system, of course, will also regulate ambient thermal by temperature estimation system in the environment and reduce energy consumption as much as possible. Table (2) shows the amount of energy management in the existing base methods, and Figure (13) shows this comparison graphically.

Table 2. The amount of energy management in the existing baseline methods

Energy Consumed	Proposed Methods	References
25 Joule	Temperature and electricity management system for smart home using decision theory or IGDT	[5]
30 Joule	Predicting the temperature in smart homes	[6]
30 Joule	Estimates and predictions of the temperature with the minimum error are obtained using 9 sensors including Wi, Tw, TL, TD, SW, T, SE, CL and CD in the smart home based on Internet of Things	[7]
32 Joule	Use fuzzy logic as a controller to adjust brightness in smart homes	[8]
34 Joule	Providing a focused lighting control system in smart homes using the Internet of objects and sensors	[9]
32.24 Joule	Using the NFC approach to control brightness in smart homes based on RGB-sensitive color sensors	[10]
34.21 Joule	Remote monitoring system to reduce costs and reduce energy consumption in sensors	[11]

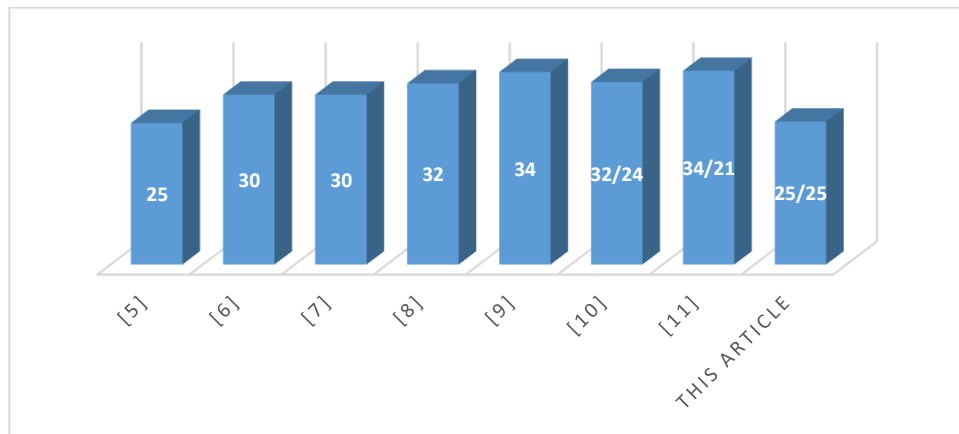
**Fig. 13.** Applied Comparison of the Proposed Approach Based on the Energy Scale with Similar Techniques

4. Conclusion

In a smart home built on the Internet of Things, this research study focused on controllers and enhanced energy usage and controller resilience. The subject of temperature estimating systems has seen the introduction of several different types of controllers. Temperature estimation systems frequently use PID controllers, which are three-part controllers with proportional, integral, and derivative portions. The fuzzy logic controller is used to enhance the PID controller parameters, which are used to maintain the PID controller parameters in various situations at the period of changing environmental conditions, in order to solve difficulties and uncertainties of the PID controller. For increased stability of the Fuzzy-PID controller, HTC is used. In the Internet of Things platform, sensors and devices communicate using the Z-WAVE and 6LoWPAN

protocols. Block Chain is used to regulate the controller's energy and stability. The primary goal of this research is to manage temperature estimate and control, and its secondary goals are to decrease energy consumption, improve energy storage, and improve heat metering. The proposed methodology has been proved to have a better outcome in terms of temperature estimate and control, as well as the amount of energy consumption and sustainability, based on the findings obtained and compared with the prior methods.

REFERENCES

- [1] F. AlFaris, A. Juaidi, and F. Manzano-Agugliaro, "Intelligent homes' technologies to optimize the energy performance for the net zero energy home,"

- Energy Build, vol. 153, pp. 262–274, 2017.
- [2] K. Gram-Hanssen and S. J. Darby, “Home is where the smart is? Evaluating smart home research and approaches against the concept of home,” *Energy Res Soc Sci*, vol. 37, pp. 94–101, 2018.
- [3] S. Tang, V. Kalavally, K. Y. Ng, and J. Parkkinen, “Development of a prototype smart home intelligent lighting control architecture using sensors onboard a mobile computing system,” *Energy Build*, vol. 138, pp. 368–376, 2017.
- [4] R. Buyya et al., “A manifesto for future generation cloud computing: Research directions for the next decade,” *ACM computing surveys (CSUR)*, vol. 51, no. 5, pp. 1–38, 2018.
- [5] A. Najafi-Ghalelou, S. Nojavan, and K. Zare, “Robust thermal and electrical management of smart home using information gap decision theory,” *Appl Therm Eng*, vol. 132, pp. 221–232, 2018.
- [6] B. Spencer and F. Al-Obeidat, “Temperature forecasts with stable accuracy in a smart home,” *Procedia Comput Sci*, vol. 83, pp. 726–733, 2016.
- [7] B. Spencer, F. Al-Obeidat, and O. Alfandi, “Selecting sensors when forecasting temperature in smart buildings,” *Procedia Comput Sci*, vol. 109, pp. 777–784, 2017.
- [8] E. Hagenbeck, N. B. Santos, R. Cavalcante, and H. Macedo, “Using fuzzy logic in smart homes lighting controllers,” in *2016 8th Euro American Conference on Telematics and Information Systems (EATIS)*, 2016, pp. 1–4.
- [9] C. Li, L. Suna, and X. Hua, “A context-aware lighting control system for smart meeting rooms,” *Systems Engineering Procedia*, vol. 4, pp. 314–323, 2012.
- [10] N. Chandrakar, S. Kaul, M. Mohan, C. S. Vamsi, and K. R. Prabhu, “NFC based profiling of smart home lighting system,” in *2015 international conference on industrial instrumentation and control (ICIC)*, 2015, pp. 338–341.
- [11] J. Včelák, A. Vodička, M. Maška, and J. Mrňa, “Smart building monitoring from structure to indoor environment,” in *2017 Smart City Symposium Prague (SCSP)*, 2017, pp. 1–5.