



# Optimal and economic programming in a reconfigured competitive electricity market considering dispersed generation sources with the firefly algorithm

Muhammad Sibtain<sup>1,\*</sup>, Snoober Saleem<sup>2</sup>

<sup>1</sup>Laboratory for Operation and Control of Cascaded Hydropower Station, China Three Gorges University, Yichang 44302, P. R. China

<sup>2</sup>Department of Economics, National University of Modern Languages, Islamabad 44000, Pakistan

## Highlights

- The majority of electric energy demanded in different countries is supplied by using fossil fuels.
- The use of renewable energy sources is essential for supplying electric energy.
- Due to the fluctuations in RES, DG units are used as microgrids to prevent problems.
- A novel two-phase method is proposed to find the optimal location and operation of DGs.
- The owners of DGs installed can bid higher prices for selling power to the grid.

## Article Info

Received: 28 May 2022

Received in revised: 26 June 2022

Accepted: 26 June 2022

Available online: 04 July 2022

## Keywords

Dispersed-generation;  
(DG)location;  
Multi-objective optimization;  
Firefly algorithm

## Abstract

Nowadays, the majority of electric energy demanded in different countries is supplied by using fossil fuels. As fossil energies are non-renewable and cause environmental pollution, the use of renewable energy sources (RES) is essential for supplying electric energy. Due to the fluctuations in RES, dispersed generation (DG) units are used as microgrids (MGs) to prevent problems in supplying the energy demanded by customers. Here, a novel two-phase method is proposed to simultaneously find the optimal location and operation of DGs. In phase 1, the DG location problem is formulated as a multi-objective problem, aiming to reduce active power losses, improve voltage profile and increase voltage. This multi-objective problem is solved by using the firefly optimization algorithm and the optimal DG location is determined. In phase 2, the revenues of DG owners and the total payment of the distribution network (DN) are calculated. The optimal sales prices of the units are also calculated by the game theory. The proposed method is implemented on a 33-bus system in MATLAB and its results are compared with PSO and GA results to demonstrate the efficiency.

## Nomenclature

Indices		Variables	
$P_{loss}$ :	Actual active power losses	$C_{inc}$	DG owners' revenue (\$)
$P_{di}$ :	Active power demanded by bus $i$	$Pf_{DG}$ :	DG operational power factor
$ S_{ni} $ :	Apparent power of bus $ni$	$\eta^{pv}$	Efficiency rate of the photovoltaic system
$i, j$	Bus indices	$\delta_{min}$ :	Minimum bus phase angle
$P_{gi}$ :	Generated active power delivered to bus $i$	$\delta_{max}$	Maximum bus phase angle
$Q_{gi}$	Generated reactive power delivered to bus $i$	$V_f$	Nominal speed of the wind turbine

\* Corresponding Author: Muhammad Sibtain

Email: [m.sibtain\\_786@yahoo.com](mailto:m.sibtain_786@yahoo.com)

$\partial share$	Maximum permissible reaction distance	$P_{Rated}$	Nominal power of the wind turbine
$Q_{di}$	Reactive power demanded by bus $i$	$C_{ope\&main}$	(\$) $DG$ Maintenance and performance price in each $T$ time interval per hour
$d_{ij}$	Reaction distance between two elements	$R_i$	Resistance of branch ( $\Omega$ ) $i$
$Y_{ij}$	The $Y_{th}$ bus of the admittance matrix of the value of element $ij$	$X_i$	Reactance of branch ( $\Omega$ ) $i$
<b>Parameters</b>		$S^{pv}$	Total level of the photovoltaic system
$T_a$	Ambient temperature	$\theta_i$	The $Y_{th}$ (order) bus of the admittance matrix of the phase angle of element $ij$
$NB$	Bus number	$C_T$	(\$/MWh) $DG_s$ Total maintenance and performance
$I_i$	Current of branch $i$	$V_{co}$	Upper cut-off speed of the wind turbine
$N_{DG}$	DG bus number	$InfR, IntR$	Inflation rate (9%) and interest rate (12.5%)
$C_{sale-DG}$	DG power sales contract price (\$/MWh)	$V_{ci}$	Lower cut-off speed of the wind turbine
$Pf_{max}^{DG}$	DG maximum permissible operational power factor	$\Delta_t$	Length of time interval $T$ per hour
$Pf_{min}^{DG}$	DG minimum permissible operational power factor		

## 1. Introduction

The daily rise in power demand has extensively developed distribution networks (DNs). DN is often radially operated due to protection and control problems. These factors increase voltage drop, losses and power imbalance as well as reducing voltage stability [1]. The use of small-scale generators that are directly connected to DNs and have local consumers prevents the establishment of power stations, transfer lines and new distribution. Systemic advantages of installing dispersed generation (DG) sources in DNs include loss reduction, voltage profile improvement, line capacity enhancement, reliability improvement and system stability promotion. Reactive power control is a practical problem in electricity engineering [2]. Disregarding this important point causes problems in grid stability and severe voltage variations. In most of the DNs, the use of devices such as engines and transformers lead to power factor lags, which reduces the usable capacity. Paying attention to the simultaneous use of active and reactive power by consumers, tendency to reduce costs and need to increase and improve power quality has motivated most of the advanced and industrial countries to daily expand reactive power compensators such as capacitor banks besides other energy sources [3]. DG sources such as wind and solar power stations can generate active and reactive power.[4] However, the extensive use of such equipment is always challenged due to the limited installable capacity, heavy costs of installing power electronic-based devices compared to capacitors and uncertainty in the wind and solar energy [5]. Various factors affect the design of power systems, including DGs. Infrastructural needs include the number and size of DG

sources, DG location and type of power grid connection. The use of DG sources can have a variety of motivations and objectives, as discussed in the literature. In [5], an optimization algorithm called the coyote optimization algorithm (ECO) was proposed. This method was applied for optimally selecting the location and capacity of DGs in radial DNs. In this multi-purpose optimization problem, the correct installation of DGs must simultaneously reduce power and cost of operations as well as promoting voltage stability. In [6], a method was introduced for optimal location and operation of battery energy storage systems (BESSs) and DGs in moderate-voltage distribution systems. A mixed-integer linear programming model was promoted to formulate the problem and an operation discretization method was introduced to solve it. In [7], an optimal DG allocation method was proposed to promote the performance of DNs and reduce environmental pollutant emissions. The proposed method aimed to maximize the advantages of using electricity in terms of reducing power losses, surplus energy sales and pollutant emission, as well as minimizing annual maintenance and operation costs. In [8], the modeling of combined heating and power systems (CHP) was comprehensively reviewed. Based on the optimal operations, this modeling was examined from five dimensions: displaying dynamic properties, improving operational flexibility, performance under uncertainty, EPS and DHS joint dispatch as well as joints DHS and EPS market clearing. In [9], a two-stage optimization method was proposed for optimal DG programming. The first stage determined the location of installation and the primary capacity of the DGs. The second stage determined the optimal DG capacity to

maximize the benefits of investment and system voltage stability as well as line losses. In [10], the performance of DG units was optimized in a competitive market by combining game theory and evolutionary algorithm. In [11], a mixed-integer linear programming optimization algorithm was introduced to determine the optimal size of DG units and BESS based on operational capacities, investment costs and estimation of environmental advantages. In [12], a comprehensive review of different concepts and applications of energy hubs in different energy consumption sectors, including residential, commercial, industrial, agricultural sectors as well as their integration, was presented. The potential role of the energy hub as an integrated energy management system was evaluated to resolve the main challenges in these sectors. By introducing the concept of smart energy hubs, this study concentrated on the benefits resulting from integrating conflict-side management, RES, DG systems, energy storage systems (ESSs) and smart technologies. In [13], a DG was proposed to minimize power losses in the distribution system based on high line resistance in the distribution system and increasing the power losses in the grid. In [14], an optimization strategy was presented for microgrids (MGs) comprising DGs, and a strategy for maximizing grid storage by using the genetic algorithm (GA) and optimal power flow (OPF). In [15], a novel optimization method was introduced, in which both optimal DG location and their generation profiles were determined based on the power demand profile and type of DGs during the DG lifetime. Diesel generation and wind turbines (WTs) constituted the DGs. This method was based on minimizing the cost of investment and operation of DGs, cost of power delivered by the external grid and the power loss costs in the grid. In [16], a smart MG comprising PV power generation, CHP system, ESS and load management was modeled to study the optimal programming strategy of these units while considering price-based demand response. To this end, an optimization model was formed for the MG economic operations. The model mainly aimed to minimize the cost of operations of the MG system and fully use clean energy while assuming distributed power generation and demand response. In [17], DERs were integrated with conventional systems as a smart solution for uninterruptible and safe power supply, even at peak load demand times. In [18], a model was presented for optimal energy management when using time-of-use (TOU) load management and critical peak market (CPM) in a microgrid. This MG comprised DG alternative generators, ESS and multi-household power demands. In [19], the distributed generations besides the Energy storages are used for improvement on reliability of

power systems. The evolutionary optimization algorithm is applied using proposed model in 30 and 69 buses IEEE systems. The blockchain model-based management strategy is applied for energy management of distributed generations in microgrid structure [20]. The new operational management strategy using complex model optimization for day-ahead market is proposed in [21]. In this model, the wind turbine and PV systems are considered in study microgrid system as undispach[22]able power sources. In [23], the global review is done for central management models of energy systems for grid-connected and islanding microgrids. In this paper also, recent papers in this field are study and compared the models. In [24], an improved coordinated optimization model beside EO algorithm is applied for PV generation systems. In this paper all of PV parameters in operational considered horizon is done for reducing power and energy losses reduction.

Most of the articles have disregarded the profit of selling electricity for DG owners and neglected the technical and economic objectives resulting from the perspective of DG owners and distribution companies. The current study resolves these deficiencies in two phases. In phase 1, the DG location problem is formulated as a multi-objective problem, aiming to reduce active power losses, improve voltage profile and increase voltage. This multi-objective problem is solved by using the firefly optimization algorithm and the optimal DG location is determined. In phase 2, the revenues of DG owners and the total payment of the distribution network (DN) are calculated by using a two-level optimization method.

## **2. DG resources**

In integrated electricity systems, based on scale savings, electric energy is centrally generated by large power stations. In the first years since the emergence of integrated systems, the systems usually faced the annual growth of 6-7% in electric energy consumption. In the 1970s, the oil crisis and environmental issues caused new problems for the electricity industry. In the 1980s, these factors coupled with economic changes and diminished power growth by 1.6-3% annually. At the same time, electric energy transfer and distribution considerably increased. Thus, central generation by large power stations has become impractical due to the reduction in power growth, increase in transfer and distribution costs, exacerbation of environmental issues and technological changes as well as enactment of different regulations [25]. In recent decades, the electricity industry reconfiguration and privatization have been proposed and implemented in some countries. To increase operational efficiency and incentivize the

inverters, the electricity industry underwent fundamental changes in terms of management and ownership. To create a competitive atmosphere, different sectors of this industry, including generation, transfer and distribution became independent. In a reconfigured electricity industry setting, it is difficult to convince the market players to invest in multi-billion-dollar projects of power generation and transfer. These evolutions, coupled with environmental pollution problems associated with the installation of new transfer lines and technological advancement in economizing the construction of small-scale generation units compared to large-scale ones have increased the use of small generation units, known as DG. DGs are mainly connected to DNs and do not need transfer lines. Most of the DG technologies are flexible in operation, size and expandability [26] The use of DGs causes a flexible reaction to electricity pricing. DGs are often designed radially where there is no generation on the load side. Therefore, the presence of a generator in the DN affects the flowing power, load voltage conditions and electric grid equipment, which can positively or negatively impact the system's operational parameters. In most of the advanced countries, the electric energy generated by DGs has evolved energy generation and distribution systems that meet all the basic needs and advantages of generation and transfer technically, academically and commercially.

DG of energy is not a new term. It emerged when people started to require different forms of energy to meet their needs because this energy is generated near its consumption place. DGs are locally used; as they are in the vicinity of consumption centers, there is no need to transfer their output electric energy to far-away places. The closer the consumer to the generator, the lower the electric energy supply costs would be. Accordingly, DG has become a good option for generation and responding to the rising consumption demands. There are different definitions for DGs, but its comprehensive definition is an electric energy source that is directly connected to the DN or the consumer side. The nominal values of these generations differ, but their generation capacity is usually from several KW to about 10 MW. These units are placed in substations and in distribution feeds in the vicinity of loads. Regardless of their method of power generation, DGs are relatively small with the capacity of < 300 MW and are directly connected to the DN [27].

### 3. Problem formulation

Technical and economic aspects of the problem are presented in two phases. The first phase is concerned with the optimal location of DGs in a radial distribution system (RDS). A multi-objective function is adopted to find the

optimal location. The second phase focuses on finding the optimal profit between the parties involved in power sales and purchase, known as the Distribution Company and DG owners. Results of the first phase, as well as the wholesale market price, are the input variables of the second phase. The game theory is adopted to find the optimal contract prices suggested by vendors (DG owners). Distribution companies select the optimal wholesale bids to minimize their final payments. These two phases are explained below:

#### A. Phase 1: Optimal DG location

The optimal DG location includes the following three objective functions:

1) Active power losses: The first objective function is active power losses that can be reduced by the optimal location of DGs. The mathematical form (pu) of the active power losses is as follows:

$$F_1 = \sum_{i=1}^{NB_r} R_i \cdot I_i^2 \quad (1)$$

2) Voltage stability index: The VSI in the second objective function aims to measure the stability of an RDS line (Fig. 1). The VSI for each bus must be positive for an optimal RDS operation. Therefore, DG can be installed and operated on the bus with the minimum VSI, in which there is high probability of voltage drop.

VSI can be obtained from the following objective:

$$VSI(i+1) = V_i^4 - 4[\hat{P}_{i+1}X_i - \hat{Q}_{i+1}R_i]^2 - 4[\hat{P}_{i+1}R_i - \hat{Q}_{i+1}X_i]^2 V_i^2 \quad (2)$$

Therefore, the second objective function for VSI is expressed as:

$$f_2 = \frac{1}{VSI(i+1)} \quad i = 1, 2, \dots, NB \quad (3)$$

3) Total voltage variations: The total voltage variations (TVV) constitute the third objective function mathematically expressed as:

$$f_3 = \sum_{i=1}^{NB} |1 - V_i| \quad (4)$$

By minimizing Equation 4, the obtained voltage profile can reduce TVV in the RDS. The proposed multi-objective problem has several constraints. These constraints, along with solving the optimization problem by optimized Equations 1, 3, and 4, are discussed below. Results of phase 1 optimization determine the optimal location of DGs which is used as the input to phase 2.

#### B. Phase 2: Seller-buyer contract optimization

DG owners aim to maximize efficiency regardless of distribution system operating conditions. The efficiency of

a DG owner depends on its revenues and costs, as considered below.

**Investment cost:** The investment cost includes the costs of installing DGs (primary costs), construction costs and equipment costs calculated from [10]:

$$C_{invs} = \sum_{m=1}^{N_{DG}} P_{DGm} \times c_{inv} \quad (5)$$

**Cost of operation and maintenance:** The cost of DG operation and maintenance includes the costs of fuels, maintenance and repair, inspection, workforce, etc., calculated using [10]:

$$C_{ope\&main} = \sum_{n=1}^{Nyr} \sum_{i=1}^T \sum_{m=1}^{N_{DG}} \Delta_t \times P_{DGm,t} \times C_T \times \left( \frac{1 + InfR}{1 + IntR} \right)^n \quad (6)$$

**DG owners' revenue:** DG owners' revenue from selling energy to the distribution company is based on the contract price. The current value of the owners' revenue is calculated by [10]:

$$C_{inc} = \sum_{n=1}^{Nyr} \sum_{i=1}^T \sum_{m=1}^{N_{DG}} \Delta_t \times P_{DGm,t} \times C_{sale-DGm} \times \left( \frac{1 + InfR}{1 + IntR} \right)^n \quad (7)$$

Note that to create competition among owners, the owner of each DG should bid his/her prices based on market prices and the prices of other units. The price proposed by the DG owner is somehow affected by and affects the distribution company's decision about the amount of power purchased from them. Still, other factors such as the DG installation location, its capacity and the lines' operational limitations impact the agreed-upon price.

1- Price of electricity purchased from the substation: The amount of power purchased from the substation by the distribution company is calculated using:

$$P_{sub,t} = \sum_{i=1}^{NB} P_{i,t} + \sum_{i=1}^{N_{Br}} R_i I_{i,t}^2 - \sum_{m=1}^{N_{DG}} P_{DGm,t} \quad (8)$$

The current value of the power purchased from the substation is calculated by [10]:

$$C_{sub} = \sum_{n=1}^{Nyr} \sum_{i=1}^T \Delta_t \times P_{sub,t} \times C_{sub-DG,t} \times \left( \frac{1 + InfR}{1 + IntR} \right)^n \quad (9)$$

2- Contract price: A two-level programming is performed by formulating the electricity contract price problem. First, DG owners bid their prices. Then, the distribution company chooses its optimal bid to minimize

payments by considering grid constraints and using optimal economic power flow. The contract price calculation formula is:

$$f_4 = \max (C_{INC} - C_{invs} - C_{ope\&main}) \quad (10)$$

$$f_5 = \min_{sub} \quad (11)$$

Here,  $f_4$  denotes the DG owners' profit. In this way, the proposed firefly algorithm calculates the optimized bid. By having the bid of DG owners, the market wholesale price and system constraints, the distribution company decides how much energy it will purchase from each seller to minimize its power payment calculated via  $f_5$ .

C. Integrating the DG location and sizing and seller-buyer contract optimization problems

In this section, the economic and technical objectives of the DG owners and programming problems are simultaneous. Due to the number of variables (size, location and contract price), the use of analytic methods with low convergence speed will not be effective. Thus, heuristic methods will be used to solve this problem.

#### 4. Constraints

The optimization problem solving involves three constraints:

1) Load-generation balance: The generated active and reactive power must be equal to the load of all buses given below:

$$\begin{aligned} P_{gni} &= P_{dni} - V_{ni} \sum_{j=1}^N V_{nj} Y_{nj} \cos(\delta_{ni} - \delta_{nj} - \theta_{nj}) \\ Q_{gni} &= Q_{dni} - V_{ni} \sum_{j=1}^N V_{nj} Y_{nj} \sin(\delta_{ni} - \delta_{nj} - \theta_{nj}) \end{aligned} \quad (12)$$

2) Voltage: The bus voltage range must fall in the optimal operating range:

$$V_{min} \leq V_{ni} \leq V_{max} \quad (13)$$

3) Current: The current in grid lines must be within the permissible limits:

$$I_i \leq I_i^{max} \quad i = 1, \dots, N_{Br} \quad (14)$$

4) Power generation constraint:

For an MG of DG units, the power generation constraint is defined as:

$$0 \leq S_{DG_i}^{max} - \frac{P_{DG_i}}{k_{pi}} * (\omega)_i^* - \omega_{DG_i} \geq 0 \quad (15)$$

$$\omega_{DG_i} \geq 0$$

$$0 \leq Q_{DG_i}^{max} - Q_{DG_i} - \frac{1}{k_{qi}} * (|V_i^*| - |V_i|) - Q_{DG_i} \geq 0 \quad (16)$$

If the power generated by DGs exceeds the determined range, the values of  $P_{DG_i}$  and  $Q_{DG_i}$  will be set in proportion to its maximum value and is converted from the horizontal form into a PQ bus.

#### 4.1. RES

Since the primary energy sources are wind turbines (WT) and PV units, the literature has used probabilistic functions to model their output power, as explained below.

#### 4.2. Probabilistic model of the PV system

in this study, the beta probability density function (PDF) is utilized to model the PV system power.

$$f(I_T^t) = \begin{cases} \frac{T(\alpha + \beta)}{T(\alpha)T(\beta)} \times I_T^{t(\alpha-1)} \times (1 - I_T^t)^{\beta-1} & \text{for} \\ 0 \leq I_T^t \leq 1, \alpha \geq 0, \beta \geq 0 \\ 0 & \text{otherwise} \end{cases} \quad (17)$$

Based on the predicted irradiation intensity distribution in each region and irradiation to power conversion function, the PV system's output power can be calculated per irradiation intensity at each time.

$$P_{PV} = \eta^{PV} \times S_T^{PV} \times I_T^t (1 - 0.005 \times (T_a - 25)) \quad (18)$$

#### 4.3. WT probabilistic model

In this study, the Rayleigh probability density function (PDF) is utilized to model the wind speed behavior. The Rayleigh distribution usually applies to random variables or vectors, the values of which are related to the vector direction component. For instance, wind speed depends on two factors: speed and direction. Assume that each factor is uncorrelated and has normal distribution with the mean 0 and equal variance. In that case, the resultant of wind speed (speed vector value) will be known by the Rayleigh distribution. Assume a variable with mixed values, the imaginary and actual parts of which are independent of each other and follow a normal distribution. The mean of these distributions is zero and their variance is equal. In this case, the absolute value of this actual value will follow a Rayleigh distribution. This distribution is named after British physicist Lord Rayleigh.

$$f(v_f^t) = (k/c) \times (v_f^t/c)^{(k-1)} e^{-(v_f^t/c)^k} \quad 0 \leq v_f^t \leq \infty \quad (19)$$

The momentary WT output power can be calculated from the power conversion function given below:

$$P_w = \begin{cases} 0 & 0 \leq v_f^t \leq v_{ci} \\ P_{rated} \times \frac{(v_f^t - v_{ci})}{(v_T - v_{ci})} & v_{ci} < v_f^t < v_T \\ P_{rated} & v_T \leq v_f^t \leq v_{co} \\ 0 & v_{co} \leq v_f^t \end{cases} \quad (20)$$

### 5. The proposed solution

Based on the problem formula, the proposed solution has two phases. Phase 1 performs the optimal location of DG, while phase 2 finds the optimal contract price.

#### 5.1. Metaheuristic algorithms

Novel methods have been developed for modeling and predicting different phenomena, among which metaheuristic algorithms have a special status. In many complex and, especially non-linear systems, the modeling, prediction and control of which are very difficult or even impossible via classic and analytical methods, metaheuristic algorithms are used owing to their knowledge- and expertise-based intelligence. Inspired by the nature, evolutionary algorithms create a population structure and grow it based on certain rules. In this method, any individual in the population is assigned a value of fitness based on its fitness function and position in the environment; then, based on certain rules, different operators are applied to each individual to promote and improve the outcome. Although biologically speaking, this method seems too simplistic, it provides a very robust and efficient adaptive search mechanism that can find the optimal solution in many complex problems. The advantages of these algorithms over the classic ones are 1) they work with the coding of the set of solutions, not the solutions themselves, and search a set of solutions, instead of searching a single solution; 2) they use the information of the objective function, not quantitative information or derivative; and 3) they utilize probabilistic transformation rules, not the deterministic ones. The current study adopted the firefly algorithm and cuckoo algorithm (as evolutionary algorithms) for simulation. The theoretical foundations of these two algorithms are discussed below.

#### 5.2. Firefly algorithm

The firefly algorithm (FA) was proposed by Yang [27]. This metaheuristic algorithm was inspired by the flashing behavior of fireflies which serves as a signaling system to attract other fireflies. In 2009, this algorithm was compared with the PSO and GA, and it was found that the FA had better efficiency and speed in finding the global optimum in some of the tested applications. In the FA, the objective function can easily be adapted to the light intensity of fireflies. The fireflies' light intensity can also be defined by a simple solution or efficiency in GA or BFA. The optimization process of FA follows variations in light intensity and attractiveness. The attractiveness of a firefly is determined based on light intensity or flashing, obtained from the objective function. In the simplest form, for optimization problems in which the maximum of the objective function is to be calculated, the maximum light  $I$  of a firefly in a unique place  $X$  can be adapted to the objective function.

$$I(X) \propto f(X) \quad (21)$$

### 6.1. The 33-bus system

The 33-bus system is depicted in Figure 3. It has 32 lines with the maximum load of MW3.72, MVar2.3, Kv12.66 with the power loss of MW0.211 [29].

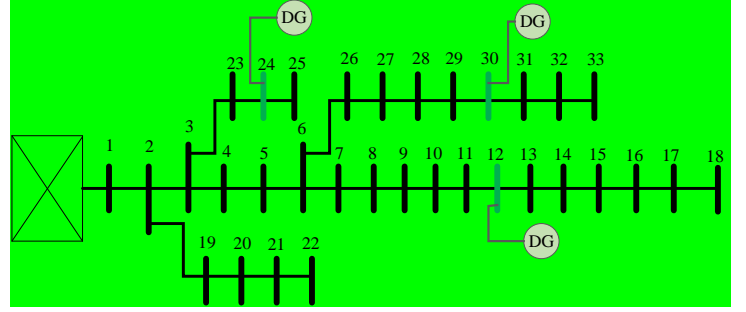

Fig. 1. The 33-bus system

Table 2 shows the non-dominated solutions obtained via MPSO in phase 1 and the results of GA and PSO for optimizing DG location.

The TVV index aims to determine the deviation from the nominal voltage per bus. When the TVV is 0, the grid has appropriate performance. Therefore, this index must be minimized to improve the voltage level. Solutions of the proposed method, PSO and GA in phase 1 are presented in Table 2. This table shows the location of DG units, active power losses, stability index and voltage setting index after DG installation. The grid demonstrated marked improvement after DG installation (Table 1). Based on Table 2, after using the DGs, the values of losses, stability index and voltage setting index are less than the case without DGs. The installation of DGs far from the substation was effective in reducing losses and improving voltage more than the installation of DGs nearby.

Table 2. Results of FA, GA and PSO

Method	Bus number (network 1) [bus1-bus2-bus3]	$f_1(p, u)$	$f_3(p, u)$	$f_2(p, u)$
FA (1)	31-29-12	0.0842	0.0524	1.0712
FA (2)	11-24-30	0.0933	0.0113	1.0492
FA (3)	12-27-30	0.0992	0.0086	1.0438
GA[29]	16-27-30	0.1312	0.0042	1.0862
PSO[30]	11-24-31	0.0803	0.0983	1.1295

Table 3 lists the standard deviation (SD), worst value (WV) and best mean (BM) of the objective function with 50 iterations for PSO, GA and FA. The indices are based on

Nevertheless, attractiveness  $\beta$  is completely relative and lies in the eyes of the beholder or is judged by other fireflies. Thus, this attractiveness changes with distance  $r_{ij}$  between firefly i and firefly j. Light intensity decreases as the distance from the source increases and the light is also absorbed in the environment. Therefore, attractiveness must be permitted to change with the absorption degree. In the simplest form, light intensity  $I(r)$  changes continuously and exponentially with distance r. Intensity is mathematically expressed below:

$$I = I_0 e^{-\gamma r} \tag{22}$$

$I_0$  is the primary light intensity and  $\gamma$  is the light absorption coefficient. The degree of absorption of a firefly is proportionate to the intensity of the light irradiated from the surrounding fireflies. Now, the attractiveness of a firefly  $\beta$  can be defined as:

$$\beta = \beta_0 e^{-\gamma r^2} \tag{23}$$

$\beta_0$  is the degree of attractiveness at distance 0. The distance between every two fireflies in  $X_i$  and  $X_j$  can be obtained from Cartesian coordinates as:

$$r_{ij} = \|X_i - X_j\| = \sqrt{\sum_{K=1}^n (X_{i,K} - X_{j,K})^2} \tag{24}$$

$X_{i,K}$  Is the kth element of firefly i.

In this algorithm, fireflies move towards more attractive fireflies. In each stage, the displacement magnitude of the attracted firefly i towards the more attractive or lighter firefly j is determined via:

$$\beta = \beta_0 e^{-\gamma r^2} \tag{25}$$

The second term of the equation is related to absorption, while the third term is stochastic and changes with a random vector that follows the normal distribution function. In most applications,  $\gamma = 1$ ,  $\beta_0 = 1$  and  $a \in [0,1]$  can be assumed.

## 6. Simulation and results

The performance of the proposed method was studied in MATLAB. Results of the DN (33-bus) by the reported parameters are discussed below. The commercial information of DGs is based on [28]. It is assumed that the load of the distribution system has 3% annual rise and the design time is considered for five years. It is also assumed that the maximum capacity of each DG is 1 MW.

Table 1. Objective function before DG installation

Network	$f_1(p, u)$	$f_2(p, u)$	$f_3(p, u)$
---------	-------------	-------------	-------------

[31]. BM displays the convergence ability of the method and SD is its stability.

**Table 3.** Results of BM, SD and WV for GA, PSO and FA (1)

	GA			PSO			FA(1)		
	D%	M	V	D%	M	V	D%	M	V
$f_1$	185	134	13	094	081	19	1034	052	03
$f_2$	356	065	11	248	171	52	034	077	25
$f_3$	034	021	09	135	08	95	056	038	82

Based on Table 4, FA has lower SD and BM than PSO and GA. This comparison shows the ability of FA in finding the appropriate location for installing the DGs.

**Table 4.** Contract equivalent price of DG units (MWh/\$)

Capacity (MW)	Contract equivalent price of DG units (MWh/\$)						
	DGs	Bus	0.2	0.4	0.6	0.8	1
DG <sub>1</sub>	21	52.5	50.2	49.3	48.3	47.7	
DG <sub>2</sub>	10	51	49.2	47.6	46.8	45.6	
DG <sub>3</sub>	28	52.4	49.3	48.2	47.5	46.4	

**Table 5.** DGs' revenue and distribution company's total payment (\$)

Capacity (MW)	DGs' revenue and distribution company's total payment (\$)						
	DGs	Bus	0.2	0.4	0.6	0.8	1
DG <sub>1</sub>	22	360234.3	412028.6	457409.6	489429.9	530485.3	
DG <sub>2</sub>	10	339003.5	370323.6	413121.8	450308.9	494009.3	
DG <sub>3</sub>	32	359012.2	388506.3	419512.3	450438.5	501653.4	
DISCO		4028785	4017193	4011003	4006197	3949015	

**Table 6.** Revenue of each DG and total payment (\$) of the distribution company

Units	Profits (\$)
DG <sub>1</sub>	558268.95
DG <sub>2</sub>	604815.21
DG <sub>3</sub>	582544.38
<b>Distributed company</b>	<b>4564986.06</b>

In phase 2, after locating the DGs, the contract price (strategies) are proposed and determined by DG owners. It is assumed that the DG generated power reaches 1 MW and increases from 0.2 MW in 0.2-MW steps. It is also assumed that the contract price proposed by DG owners has a value between 45 and 55 (MWh/\$) and rises in steps of 0.1

(MWh/\$). Table 5 lists the contract price calculated in phase 2 by the proposed method. The DG revenue and total payment of the distribution company are given in Table 5. Results in Tables 4 and 5 present the optimal solution for the contract price problem with the proposed method. Table 5 shows that the distribution company's payment is reduced, while DGs' revenue is increased by increasing their capacity.

Figure 2 illustrates the voltage profile level in the presence and absence of DG. When DG is applied to the system, the voltage level is markedly increased and the system has better stability than the case without DG. The case without DG has great fluctuation in the voltage profile.



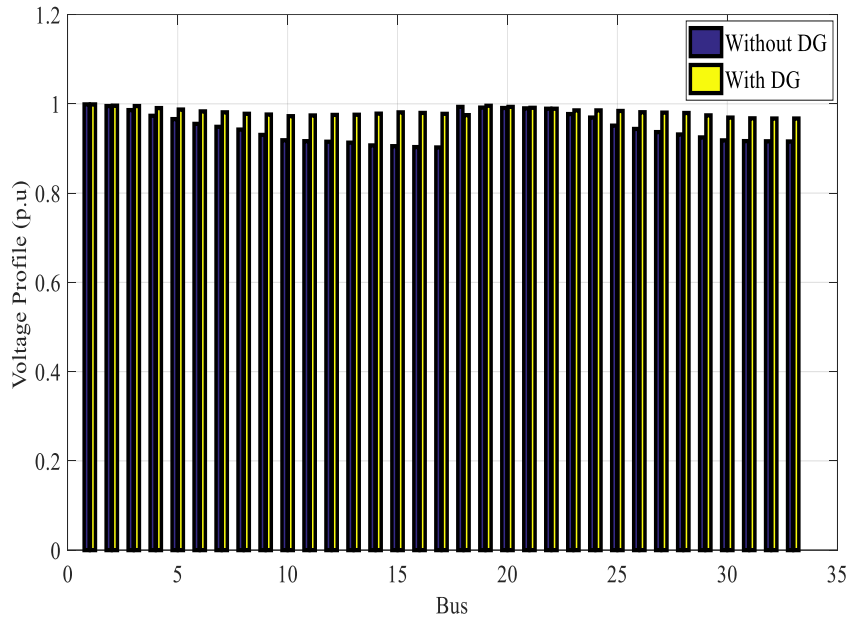

**Fig. 2.** Voltage level with and without DG

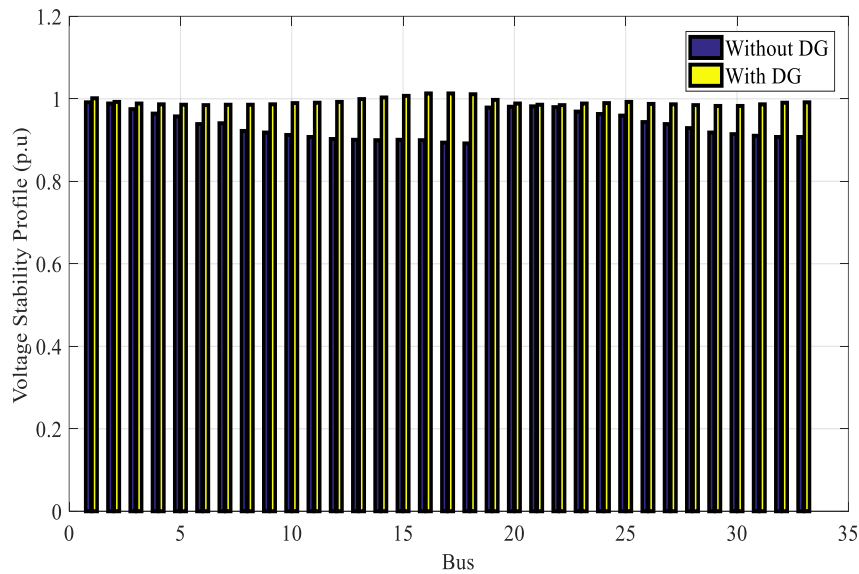

**Fig. 3.** VSI with and without DG

Fig (3) shows the VSI in the presence and absence of DG. When there is DG in the grid, voltage is better supplied, while in the absence of DG, this status is unstable.

**Table 7.** Simultaneous economic and technical objectives of DG owners and DISCO

<b>Fitness</b>	<b>Values</b>
$f_1(p, u)$	0.163501
$f_1(p, u)$	1.19508
$f_1(p, u)$	0.12748
DG's location	18-22-30
DG's size (MW)	0.8 – 0.7 – 0.9

In phase 3, as we aim to minimize the functions but maximize  $f_4$ , this function is multiplied by -1 and included in the optimization problem. To find the final solution from the Pareto, the solution with lower deviation in voltage is taken into account. The data, e.g., DG size and location, voltage profile indices, losses and voltage stability, are given in Table 7. Evidently, voltage profile indices are declined and voltage stability rises.

Fig (4) and 5 aim to display variations in voltage profile and voltage stability, and show improvement in these indices.

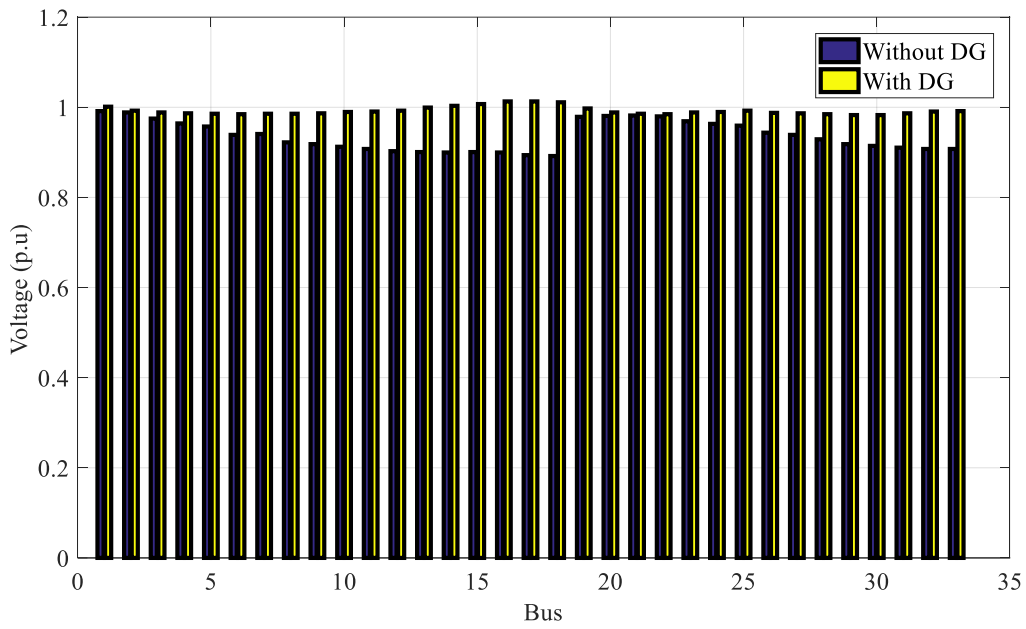

**Fig. 4.** Voltage profile under the simultaneous effect of both phases of the problem

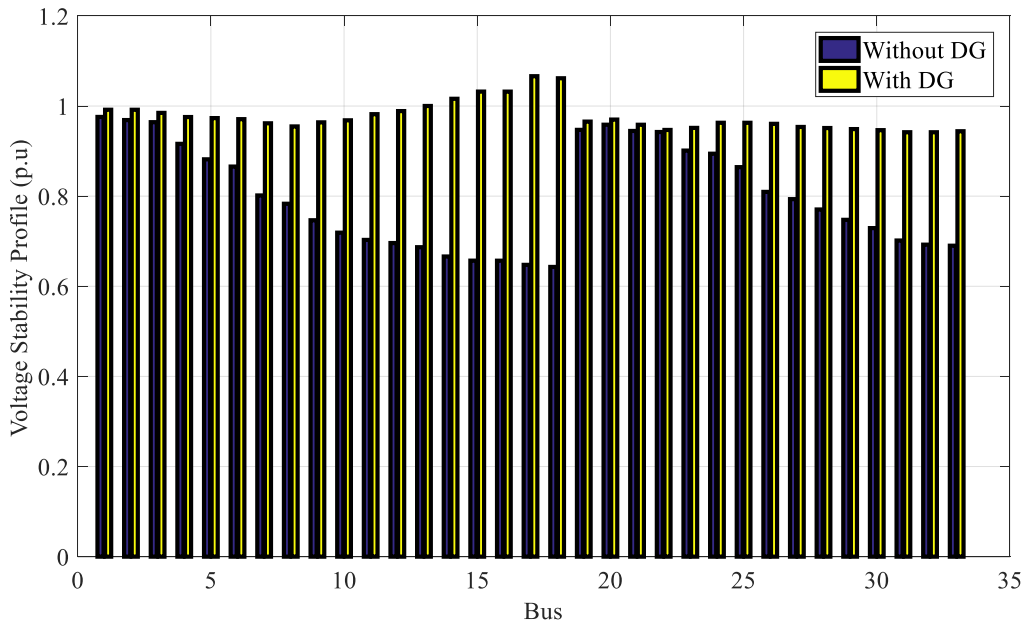

**Fig. 5.** Voltage stability under the simultaneous effect of both phases of the problem

The proposed method helped both DG owners and the distribution company gain optimal profit by increasing the capacity of DG units (Table 5). Such economic benefits

accompany improved technical aspects. Voltage setting indices and grid stability were improved besides losses. Results are discussed in phase 1 of the proposed algorithm.

Note that the lowest contract price and profit belong to DG2 (Tables 4 and 5). As DG2 is near the substation, its effect on grid loss mitigation is not comparable to that of other units. The distribution company gains no benefit from purchasing more expensive energy from DG2 than the wholesale price proposed in the substation. This term holds for DG units when they are installed far from heavy loads.

## 7. Conclusion

This paper used fundamental concepts of multi-objective optimization and proposed a novel method based on the firefly optimization algorithm for optimal DG location and sizing. The findings proved the ability of the new algorithm in optimization. The proposed method was developed in two phases. In phase 1, a multi-objective optimization problem was formulated as power loss reduction, voltage stability and voltage profile improvement to find the optimal location of DGs. In phase 2, the optimal DG operation was obtained by developing a two-level objective function. This objective function maximized DG owners' revenue and minimized the distribution company's payment through finding optimal contract prices. The results revealed that the competition among DG units enabled the distribution company to purchase energy at a lower price than DG units.[30,31] Moreover, installing DGs near the substation would not be effective, while DGs far from the substation can be more effective in reducing power losses and enhancing voltage profile. The owners of DGs installed farther from the substation can bid higher prices for selling power to the grid. In the future works, its try to illustrate the effectiveness of Energy storage and demand side management effect of management strategy in microgrid resources.

## REFERENCES

- [1] Panda M, Nayak YK. Impact analysis of renewable energy Distributed Generation in deregulated electricity markets: A context of Transmission Congestion Problem. *Energy* 2022;124403.
- [2] Lotfi H, Shojaei AA. A dynamic model for multi-objective feeder reconfiguration in distribution network considering demand response program. *Energy Systems* 2022:1–30.
- [3] Kuspan B, Bagheri M, Abedinia O, Naderi MS, Jamshidpour E. The influence of electric vehicle penetration on distribution transformer ageing rate and performance. 2018 7th International Conference on Renewable Energy Research and Applications (ICRERA), IEEE; 2018, p. 313–8.
- [4] Mobarakeh AI, Sadeghi R, Delshad M. Techno-economic energy management of micro-grid in the presence of distributed generation sources based on demand response programs. *International Journal of Electrical Power & Energy Systems* 2022; 141:108169.
- [5] Nurmanova V, Sultanbek A, Bagheri M, Ahangar RA, Abedinia O, Phung T, et al. Distribution Transformer Frequency Response Analysis: Behavior of Different Statistical Indices During Inter-Disk Fault. 2019 IEEE International Conference on Environment and Electrical Engineering and 2019 IEEE Industrial and Commercial Power Systems Europe (EEEIC/I&CPS Europe), IEEE; 2019, p. 1–6.
- [6] Chabok H, Aghaei J, Sheikh M, Roustaei M, Zare M, Niknam T, et al. Transmission-constrained optimal allocation of price-maker wind-storage units in electricity markets. *Applied Energy* 2022; 310:118542.
- [7] Abo El-Ela AA, Allam SM, Shaheen AM, Nagem NA. Optimal allocation of biomass distributed generation in distribution systems using equilibrium algorithm. *International Transactions on Electrical Energy Systems* 2021;31: e12727.
- [8] Zhang M, Wu Q, Wen J, Lin Z, Fang F, Chen Q. Optimal operation of integrated electricity and heat system: A review of modeling and solution methods. *Renewable and Sustainable Energy Reviews* 2021; 135:110098.
- [9] Li Y, Feng B, Li G, Qi J, Zhao D, Mu Y. Optimal distributed generation planning in active distribution networks considering integration of energy storage. *Appl Energy* 2018; 210:1073–81.
- [10] RUZBEHI S, MORADI MH. OPTIMAL OPERATION OF GD UNITS IN A COMPITITIVE MARKET VIA GAME THEORY AND EVOLUTIONARY ALGORITM 2016.
- [11] Strnad I, Prenc R. Optimal sizing of renewable sources and energy storage in low-carbon microgrid nodes. *Electrical Engineering* 2018; 100:1661–74.
- [12] Mohammadi M, Noorollahi Y, Mohammadi-ivatloo B, Hosseinzadeh M, Yousefi H, Khorasani ST. Optimal management of energy hubs and smart energy hubs—a review. *Renewable and Sustainable Energy Reviews* 2018; 89:33–50.
- [13] Khalesi N, Rezaei N, Haghifam M-R. DG allocation with application of dynamic programming for loss reduction and reliability improvement. *International Journal of Electrical Power & Energy Systems* 2011; 33:288–95.
- [14] Mohammadi M, Hosseinian SH, Gharehpetian GB. GA-based optimal sizing of microgrid and DG units under pool and hybrid electricity markets. *International Journal of Electrical Power & Energy Systems* 2012; 35:83–92.
- [15] Ghanbari N, Mokhtari H, Bhattacharya S. Optimizing operation indices considering different types of distributed generation in microgrid applications. *Energies (Basel)* 2018; 11:894.

- [16] Wang Y, Huang Y, Wang Y, Zeng M, Li F, Wang Y, et al. Energy management of smart micro-grid with response loads and distributed generation considering demand response. *J Clean Prod* 2018; 197:1069–83.
- [17] Sarangi S, Sahu BK, Rout PK. Distributed generation hybrid AC/DC microgrid protection: A critical review on issues, strategies, and future directions. *International Journal of Energy Research* 2020; 44:3347–64.
- [18] Samuel O, Javaid N, Ashraf M, Ishmanov F, Afzal MK, Khan ZA. Jaya based optimization method with high dispatchable distributed generation for residential microgrid. *Energies (Basel)* 2018; 11:1513.
- [19] Hamidan M-A, Borousan F. Optimal planning of distributed generation and battery energy storage systems simultaneously in distribution networks for loss reduction and reliability improvement. *Journal of Energy Storage* 2022; 46:103844.
- [20] Bian Z, Zhang Q. Combined compromise solution and blockchain-based structure for optimal scheduling of renewable-based microgrids: Stochastic information approach. *Sustainable Cities and Society* 2022; 76:103441.
- [21] Elgamal M, Korovkin N, Menaem AA, Elmitwally A. Day-ahead complex power scheduling in a reconfigurable hybrid-energy islanded microgrid with responsive demand considering uncertainty and different load models. *Applied Energy* 2022; 309:118416.
- [22] Roslan MF, Hannan MA, Ker PJ, Mannan M, Muttaqi KM, Mahlia TMI. Microgrid control methods toward achieving sustainable energy management: A bibliometric analysis for future directions. *Journal of Cleaner Production* 2022:131340.
- [23] Eid A, Kamel S, Houssein EH. An enhanced equilibrium optimizer for strategic planning of PV-BES units in radial distribution systems considering time-varying demand. *Neural Computing and Applications* 2022:1–29.
- [24] Singh B, Sharma J. A review on distributed generation planning. *Renewable and Sustainable Energy Reviews* 2017; 76:529–44.
- [25] Lopes JAP, Hatziargyriou N, Mutale J, Djapic P, Jenkins N. Integrating distributed generation into electric power systems: A review of drivers, challenges and opportunities. *Electric Power Systems Research* 2007; 77:1189–203.
- [26] Abdmouleh Z, Gastli A, Ben-Brahim L, Haouari M, Al-Emadi NA. Review of optimization techniques applied for the integration of distributed generation from renewable energy sources. *Renewable Energy* 2017; 113:266–80.
- [27] Yang X-S. Firefly algorithms for multimodal optimization. *International symposium on stochastic algorithms*, Springer; 2009, p. 169–78.
- [28] Mohammadi M, Hosseini SH, Gharehpetian GB. GA-based optimal sizing of microgrid and DG units under pool and hybrid electricity markets. *International Journal of Electrical Power & Energy Systems* 2012; 35:83–92.
- [29] Moradi MH, Abedini M. A combination of genetic algorithm and particle swarm optimization for optimal DG location and sizing in distribution systems. *International Journal of Electrical Power & Energy Systems* 2012; 34:66–74.
- [30] Faria P, Soares J, Vale Z, Morais H, Sousa T. Modified particle swarm optimization applied to integrated demand response and DG resources scheduling. *IEEE Transactions on Smart Grid* 2013; 4:606–16.
- [31] Moradi MH, Abedini M, Hosseini SM. A combination of evolutionary algorithm and game theory for optimal location and operation of DG from DG owner standpoints. *IEEE Transactions on Smart Grid* 2015; 7:608–16.